

OPERABLE WALLS
Panelfold®
Modulflex®
SERIES 400
 Individual
 Panels

Model
 410 MD
 Multi-
 Directional

PRODUCT BRIEF

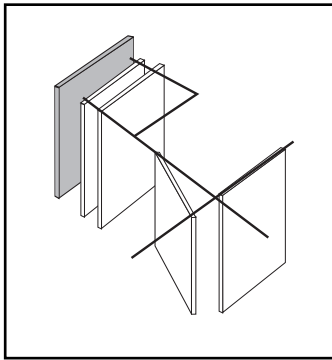

OPERATING FEATURES.
Modulflex Model 410 MD Multi-directional, Individual panels, each supported with two glide discs or horizontal rotating ball-bearing carrier assemblies easily negotiate 90° 2,3 and 4 way track intersections. Each panel can be turned in any direction, anywhere along the track grid. Heights to 14'0" (4267).

ACOUSTICAL PERFORMANCE.
Modulflex Series 400 operable walls have attained ratings of STC 47, STC 44, STC 42 and STC 38.

PANEL FINISHES. A full range of vinyl, panel fabric, wood veneers, high pressure laminates and wall carpet as well as Customer's Own Materials is offered.

TYPES OF CLOSURES

See pages 2,3 and 4 for details.

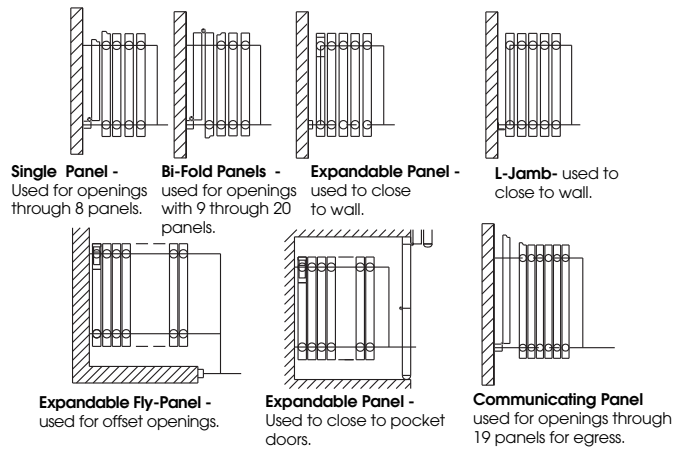

OPTIONS AND ACCESSORIES

ELEVATION

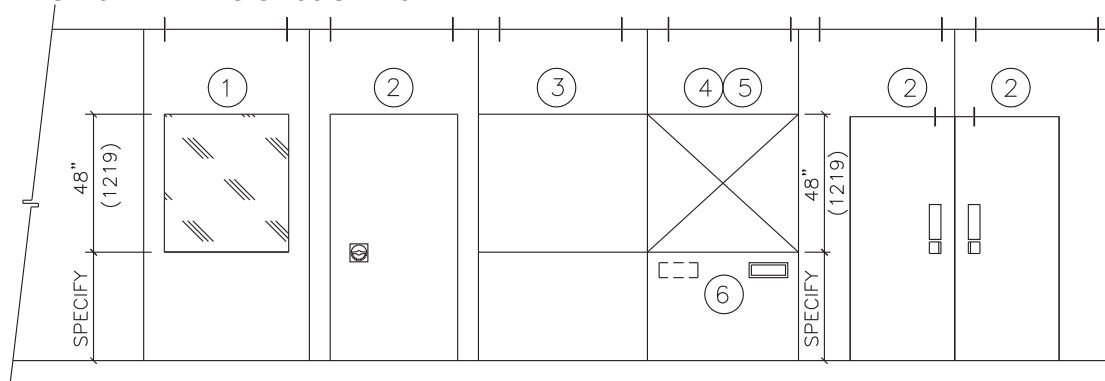

OPTIONS SPECIFICATIONS

See page 8 for Product Specifications

- ① WINDOWS where indicated on the plans shall be nominally (specify: 48" (1219) high; or full panel height). Windows shall be (specify: factory glazed with 1/4" (6) clear acrylic; or unglazed, framed opening only). Windows shall be bronze trimmed.
- ② SINGLE PASS DOORS where indicated shall be nominally (specify: 3'0" (914); or 2'8" (813)) wide by (specify: 6'8" (2032); or 7'0" (2134)) high. Doors shall be manufactured of the same materials and thickness as the panels and be equipped with butt-type hinges and positive latches with drop cup and ring pulls. Double doors have roller latches. Options: deadbolt locks; self illuminated exit signs; hydraulic door closers; A.D.A. compliant friction roller latch with flush pulls.
- ③ TACKBOARDS where indicated shall be nominally (specify: 48" (1219)) high; or full panel height). Tackboards shall consist of 1/4" (6) cork surfaced with minimum 30oz per lineal yard Type II Fabrictex vinyl fabric (color to be selected from manufacturer's standards) and bronze trimmed.
- ④ CHALKBOARDS where indicated shall be nominally (specify: 48" (1219) high; or full panel height). Chalkboards shall be chalkable porcelain enameled steel (color to be selected from manufacturer's standards) and bronze trimmed.
- ⑤ MARKERBOARDS where indicated shall be nominally (specify: 48" (1219) high; or full panel height) and be of suitable non-porous surfaced porcelain enameled steel for application of write-on, wipe-off marker pens. Color of markerboards to be selected from manufacturer's standards and bronze trimmed.
- ⑥ RECESSED TRAY for storing chalk or marking pens and erasers shall be installed where indicated and shall be bronze color.

FURTHER INFORMATION. All dimensions shown in parentheses are millimeters. **Modulflex Series 400** operable walls have three inch thick panels for general purpose applications and are supplied with Manuseal™ clearance type bottom seal mechanisms that are actuated by a removable tool.
 Scale N.T.S.



Moduflex® SERIES 400
Individual Panels Model 410 MD

TYPES OF CLOSURES AND PANEL STACKING

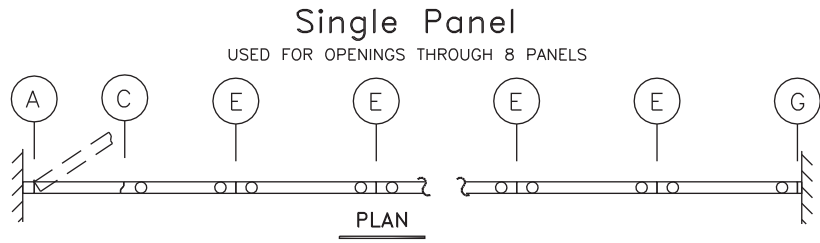
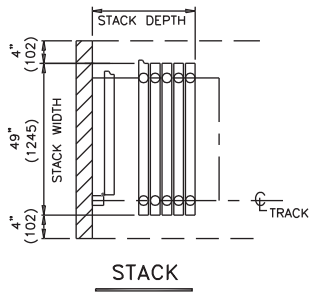

STACK DEPTH = NO. PANELS X 3.625" (92) PLUS 3 1/2" (89)

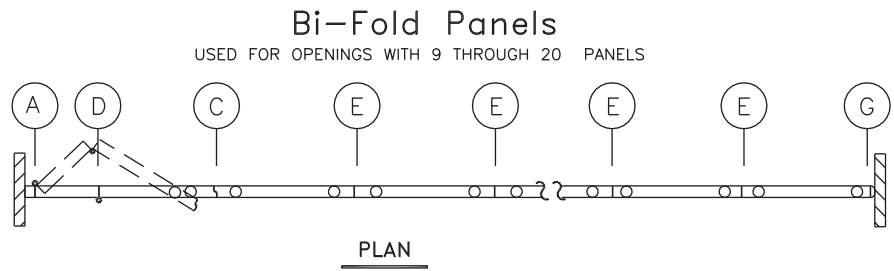
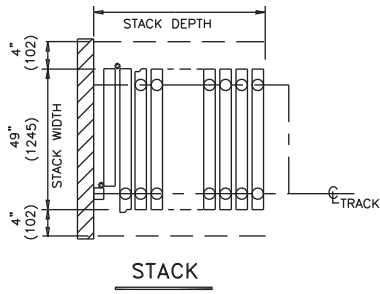

STACK DEPTH = NO. PANELS X 3.625" (92) PLUS 3 1/2" (89)

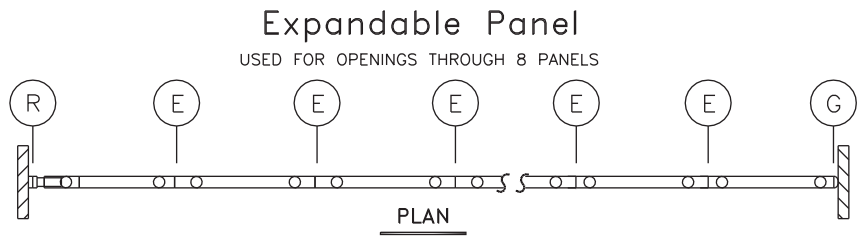
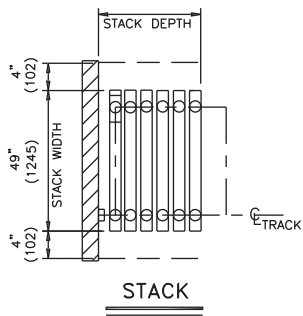

STACK DEPTH = NO. PANELS X 3.625" (92) PLUS 3 1/2" (89)

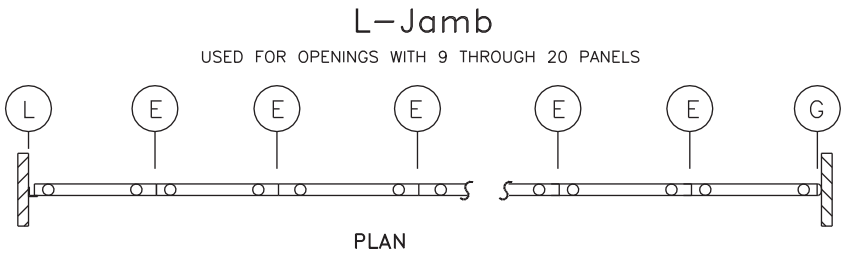
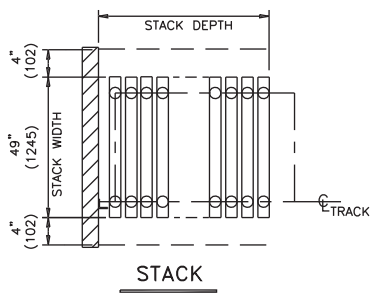

STACK DEPTH = NO. PANELS X 3.625" (92) PLUS 3 1/2" (89)



Moduflex® SERIES 400
Individual Panels Model 410 MD

TYPES OF CLOSURES AND PANEL STACKING

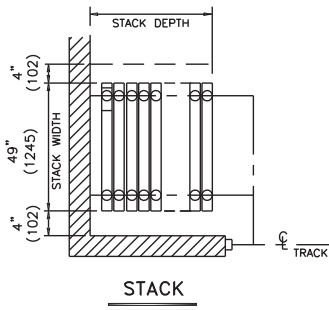

Expandable Panel
USED FOR OFF-SET OPENINGS

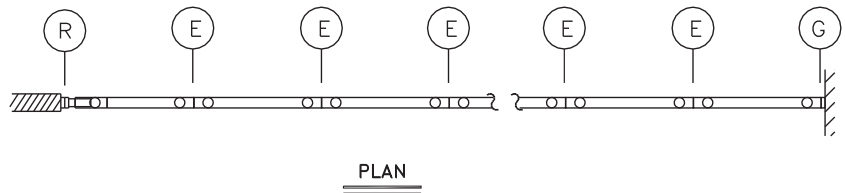

STACK DEPTH = NO. PANELS X 3.625" (92)

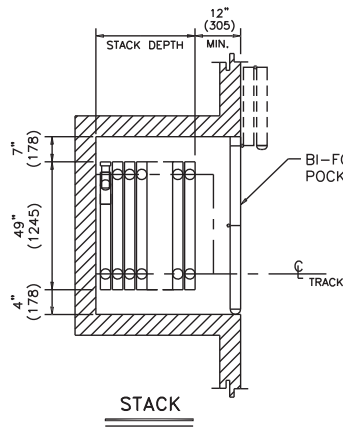

Expandable Panel
USED TO CLOSE TO POCKET DOOR

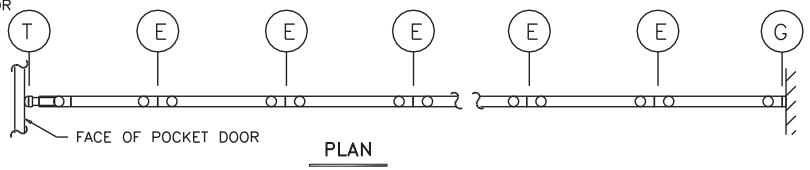

STACK DEPTH = NO. PANELS X 3.625" (92)

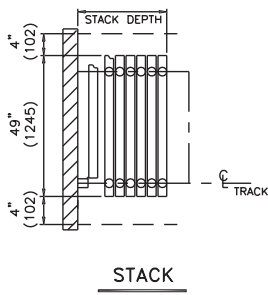

Communicating Panel
USED FOR OPENINGS THROUGH 19 PANELS

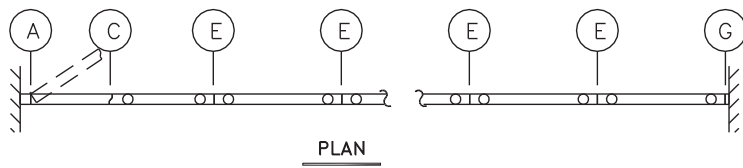

STACK DEPTH = NO. PANELS X 3.625" (92) PLUS 3 1/2" (89)



Moduflex SERIES 400

Individual Panels Model 410 MD

JAMBS AND PANEL INTERLOCKING DETAILS

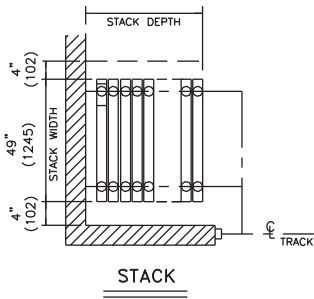

Expandable Panel
USED FOR OFF-SET OPENINGS

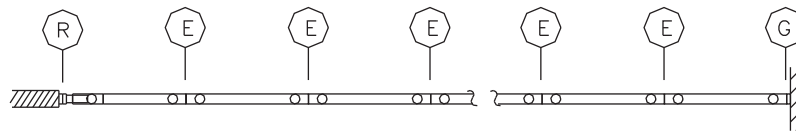

$$\text{STACK DEPTH} = \text{NO. PANELS} \times 3.625" (92)$$

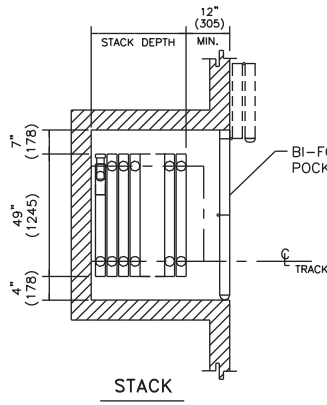

Expandable Panel
USED TO CLOSE TO POCKET DOOR

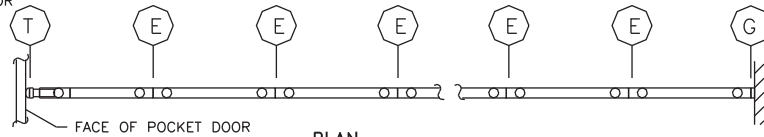

$$\text{STACK DEPTH} = \text{NO. PANELS} \times 3.625" (92)$$

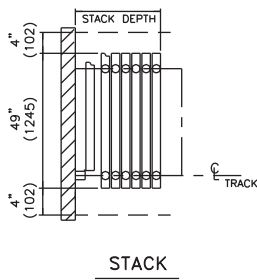

Communicating Panel
USED FOR OPENINGS THROUGH 19 PANELS

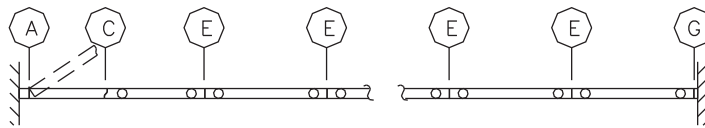

$$\text{STACK DEPTH} = \text{NO. PANELS} \times 3.625" (92) \text{ PLUS } 3 \frac{1}{2}" (89)$$



Moduflex® SERIES 400

Individual Panels Model 410 MD

VERTICAL SECTION - HEAD DETAILS - TYPE 1 ALUMINUM TRACK HEIGHTS TO 10' (3048)

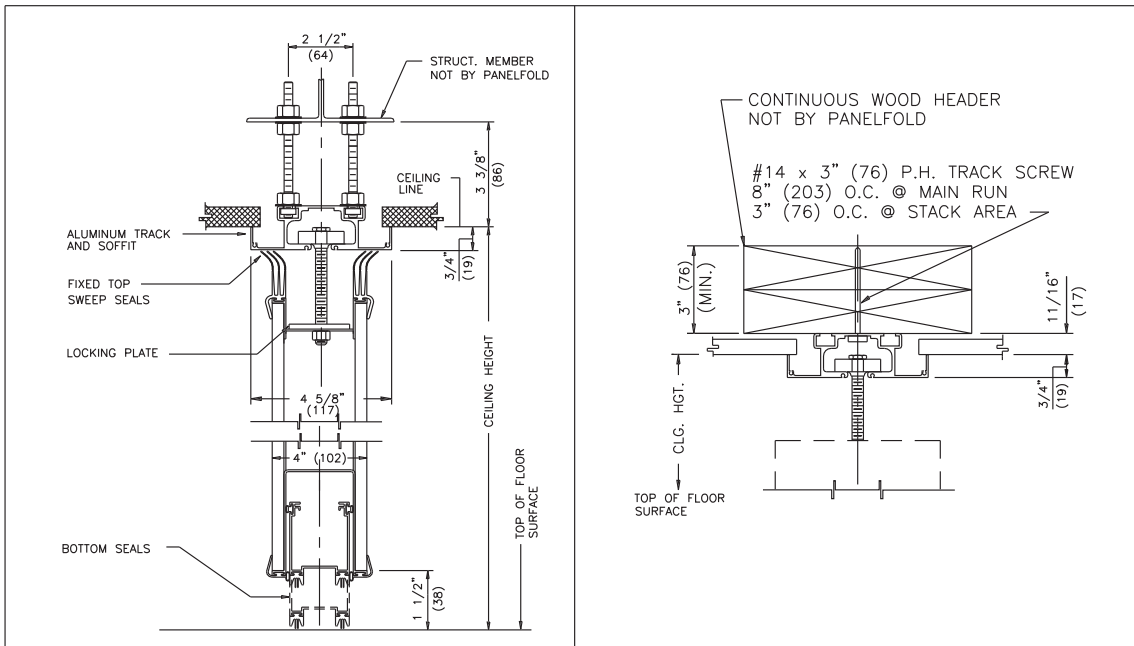

TYPE 1 TRACK
HANGER ROD SUSPENSION

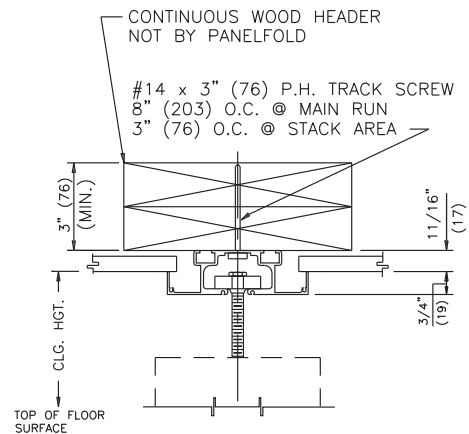

TYPE 1 TRACK
DIRECT MOUNT

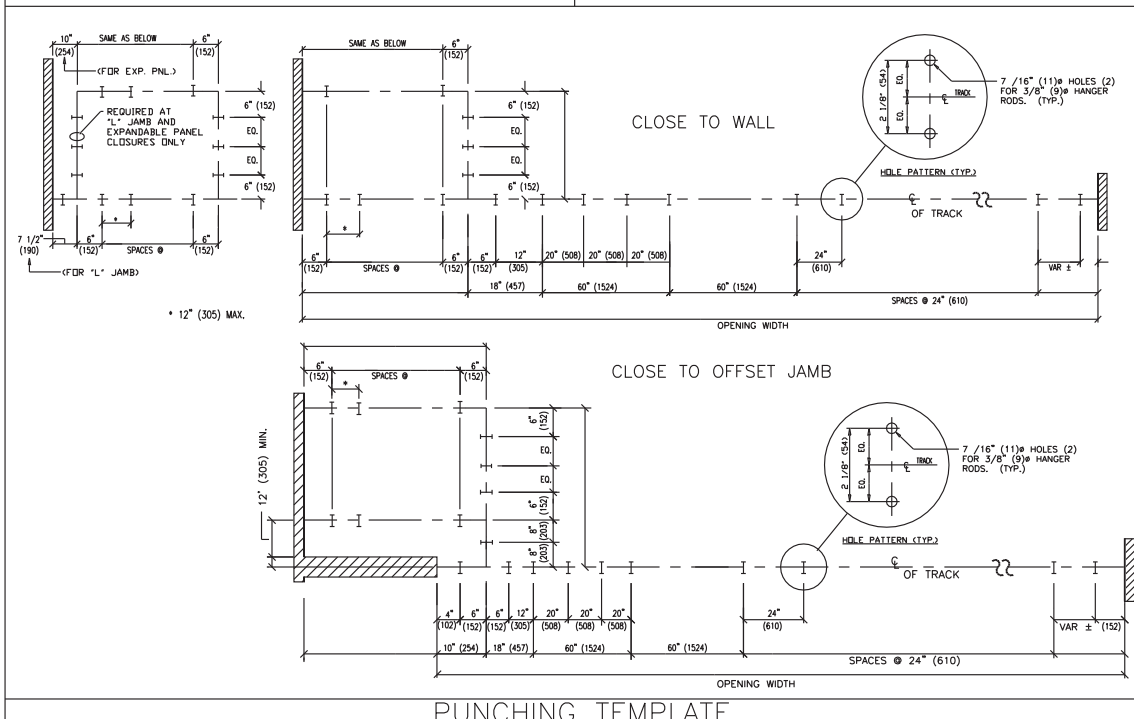

PUNCHING TEMPLATE

All dimensions shown in parentheses are millimeters. Scale: N.T.S.



Moduflex® SERIES 400

Individual Panels Model 410 MD

VERTICAL SECTION - HEAD DETAILS - TYPE 9 ALUMINUM TRACK
HEIGHTS TO 14'0" (4267)

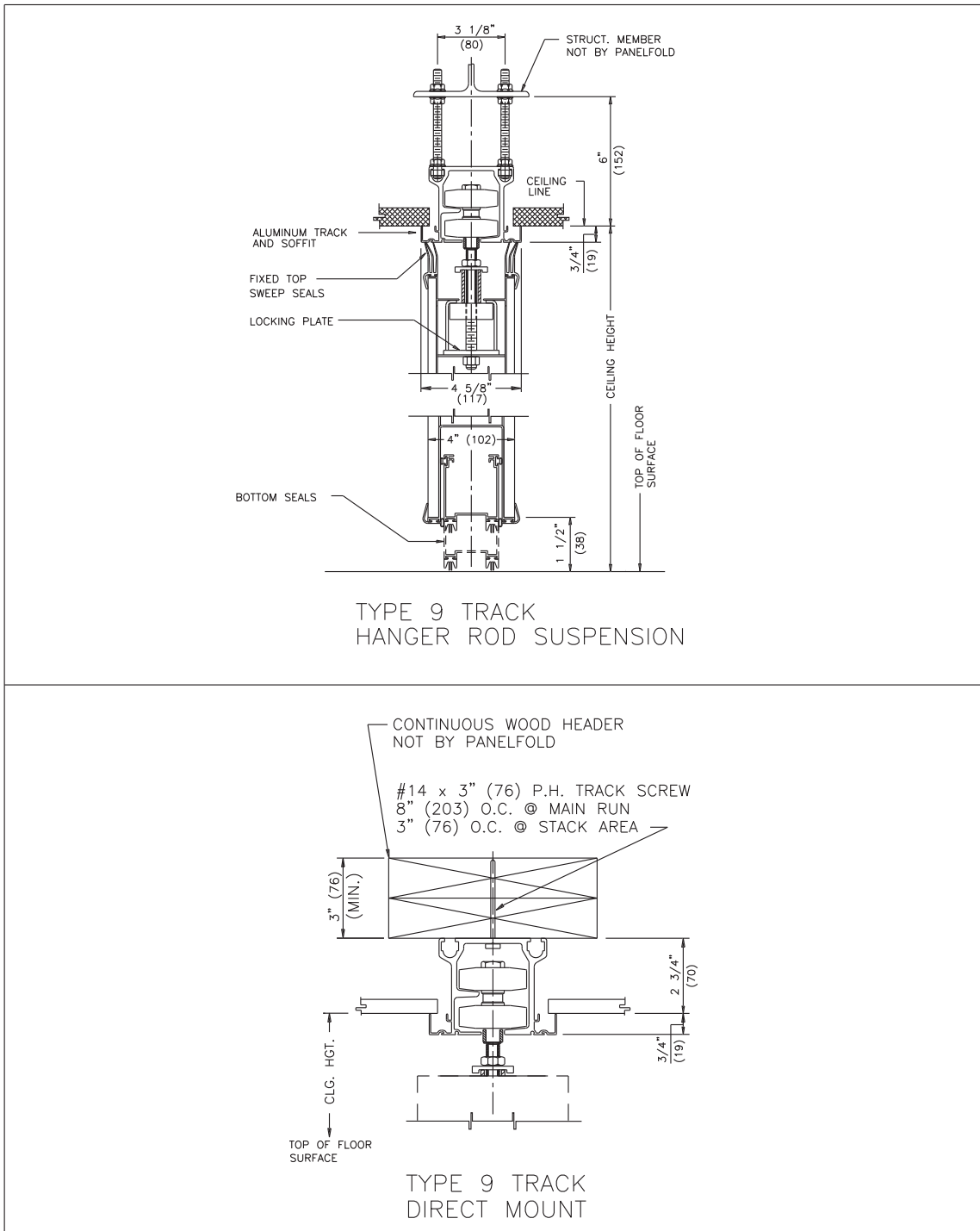

All dimensions shown in parentheses are millimeters. Scale: N.T.S.



Moduflex® SERIES 400

Individual Panels Model 410 MD

TYPE 9 ALUMINUM TRACK - PUNCHING TEMPLATE

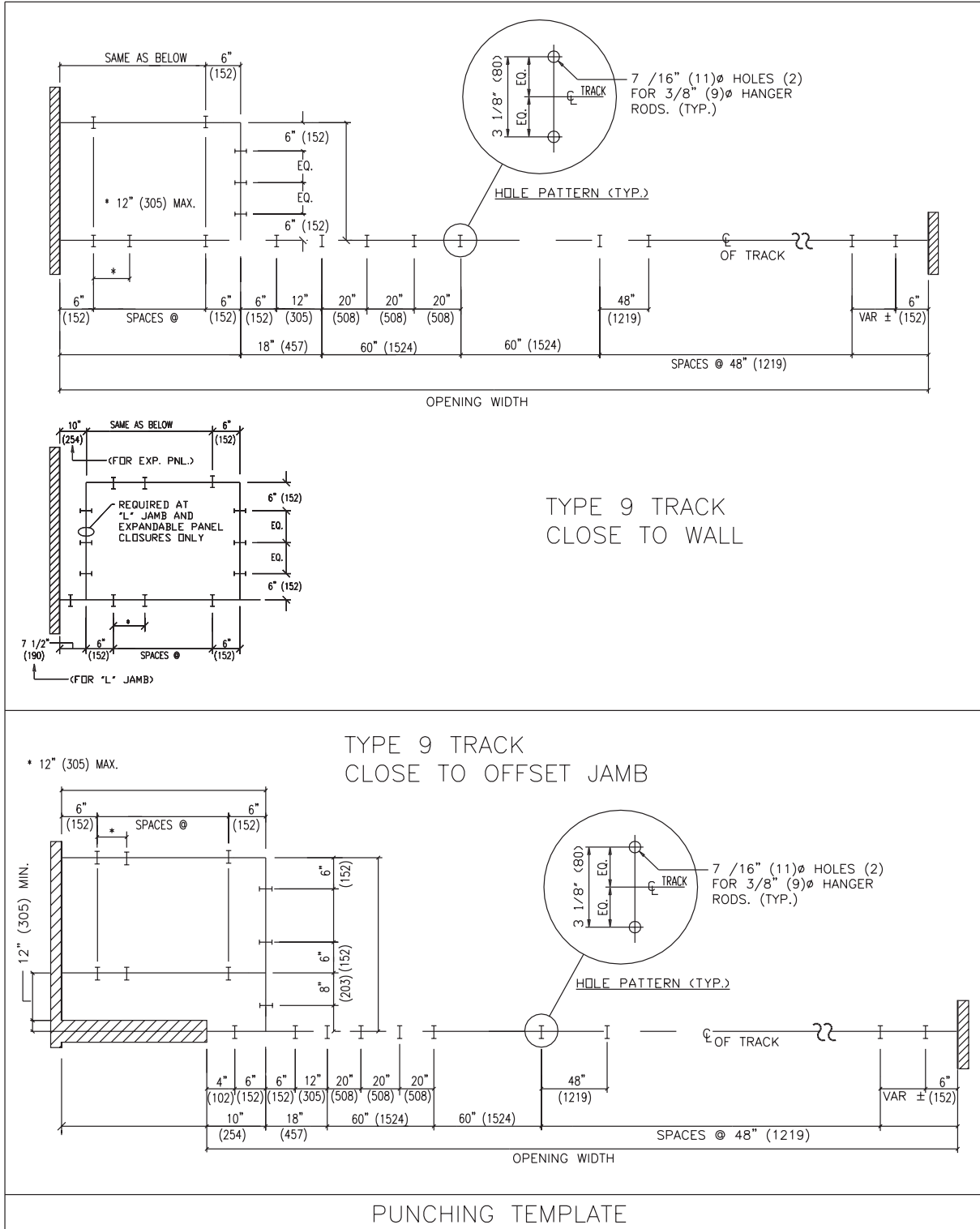

All dimensions shown in parentheses are millimeters. Scale: N.T.S.

Moduflex® SERIES 400

Individual Panels Model 410MD (Multi-Directional)

PRODUCT SPECIFICATIONS: SECTION 10650 - OPERABLE WALLS

PART 1 GENERAL

(See Project Guide Specifications for Scope, Related Work, References, Submittals, Product Delivery and Acceptable Manufacturers paragraphs.)

PART 2 PRODUCTS

- 2.1 OPERABLE WALLS** shall be manufactured by Panelfold, Inc., Miami, Florida, U.S.A. and installed by an authorized representative of the manufacturer in openings prepared by others to Moduflex® Series 400 requirements.
- 2.2 OPERATION** shall consist of a series of manually operated flat panels, top supported. Top and bottom seals shall be as specified in paragraph 2.9.
- 2.3 PANEL CONFIGURATION** shall be as follows for areas indicated on the plans:
- 2.3.1 MODEL 410 shall be comprised of a series of multi-directional individual panels, side or remote stacking (located in room(s)).
- 2.3.2 Final closure shall be effected by (specify: Jamb-Hinged single or bi-fold Panels; Expandable Panels; or Jamb-Hinged Communicating Panels).
- 2.4 PANELS** shall be 3" (76) thick and nominally 49" (1245) wide. Panel faces shall be laminated to metal frames. Panels shall have appropriate internal insulation to achieve specified STC. The tops of the panels shall be reinforced to support suspension components.

The vertical edges of the panels shall not require trim thus minimizing the appearance of the vertical joining of the Sheer-Look® panels.

- 2.5 PANELS** shall be factory surfaced with one of the following (colors to be selected from manufacturer's standards):
- 2.5.1 Manufacturer's standard vinyl, Class A flame spread (specify Type I; or Type II).
- 2.5.2 Manufacturer's standard Ribtex® Basic, vertical-rib wall carpeting, Class A.
- 2.5.3 Manufacturer's Woventex® panel fabric, Class A, acrylic latex backed.
- 2.5.4 Maharam Tekwall panel fabric, Class A, acrylic backed.
- 2.5.5 Genuine unfinished wood veneer shall be (specify: White Ash, Red Oak, Natural Birch, American Walnut or other species as specified).
- 2.5.6 High pressure laminate, vertical grade.
- 2.5.7 Customer's Own Material to be factory applied (subject to approval by the manufacturer for suitability to standard manufacturing processes and equipment).
- 2.5.8 Unsurfaced panel skins for field finishing by others.

- 2.6 HANGING WEIGHT** of panels shall not exceed 8 lbs./ft² (39 kg/m²).
- 2.7 ACOUSTICAL RATING** as tested by an independent acoustical laboratory in accordance with ASTM E90-81 test procedures in a full scale 14'0" (4267) by 9'3" (2819) opening shall be (specify: STC 47, STC 44, STC 42 or STC 38).
- 2.8 ECHOSORB™ ACOUSTICAL WALL PANELS** shall be provided where shown on the plans. Acoustical panels shall have obtained an NRC .75 rating per ASTM 423. Panels shall be provided with quick mounting and dis-mounting hardware requiring no tools. Acoustical transparent fabric to be selected from manufacturer's standards.
- 2.9 SOUND SEALS** shall be as follows:
- 2.9.1 Vertical seals between panels shall consist of deep nesting, universal interlocking ESP bronze steel astragals incorporating continuous, vinyl acoustical seals. Vertical astragal vinyl seals shall be installed on the outboard edges of the panel skins in a double row with an acoustical labyrinth.
- 2.9.2 Horizontal TOP seals shall be (specify: continuous contact extruded vinyl shapes; or clearance type, automatically actuated; or clearance type, manually actuated).
- 2.9.3 Horizontal BOTTOM seals shall be 1 1/2" (38) clearance-type manually actuated at waist height on panel edges). Downward pressure of all clearance-type seal mechanisms shall assure an acoustical seal and resist panel movement.
- 2.10 SUSPENSION SYSTEM** shall be heavy duty aluminum multi-directional (specify: type 1, or type 9) track. Track shall be supported by (specify: adjustable steel hanger rods; or direct mount). Each panel shall be supported by two carrier assemblies of (specify: glide discs, or dual horizontal rotating ball bearing wheels). Carrier assemblies shall be attached to the panels with adjustable steel pendant bolts with locks to prevent panel misalignment.
- 2.11 PANELS** that are hinged together shall be hinged with manufacturer's standard butt-type hinges.
- 2.12 POCKET DOORS** where indicated on the plans shall be manufactured of the same materials as the panels. Hinges shall be standard butt-type.

PART 3 EXECUTION

(See Project Guide Specifications for Execution, Installation, Cleaning and Demonstration paragraphs).

- NOTE:** The ASTM - 84 procedure Class A flame spread and other test results referenced herein are for comparison purposes only and are not intended to reflect hazards presented by this or any other materials under actual fire conditions.

For further information, or additional technical information, contact your Panelfold distributor.

Panelfold®

FOLDING DOORS • ACOUSTICAL FOLDING PARTITIONS • ACOUSTICAL PANELS
OPERABLE WALLS • RELOCATABLE WALLS

Panelfold, Inc. P.O. Box 680130, Miami, Florida 33168
(305) 688-3501 • FAX: (305) 688-0185

8. Internet: www.panelfold.com • E-mail: sales@panelfold.com