

OPERABLE WALLS
Panelfold®
Moduflex®
 SERIES 600
 Individual
 Panels
 Model
 610 PP
 Pre-
 Programmed

PRODUCT BRIEF

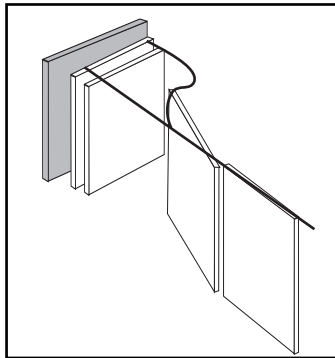

OPERATING FEATURES.
Moduflex Model 610PP
 Individual panels top supported by radial type, steel ball-bearing wheels, move one panel at a time and are pre-programmed to make up openings and store the same way every time. Heights to 24'0" (7315).

ACOUSTICAL PERFORMANCE.
Moduflex Series 600 operable walls have attained ratings of STC 50, STC 47, and STC 45.

PANEL FINISHES. A full range of vinyl, panel fabric, wood veneers, plastic laminate and wall carpet as well as Customer's Own Materials is offered.

TYPES OF CLOSURES
 See pages 2,3 and 4 for details.

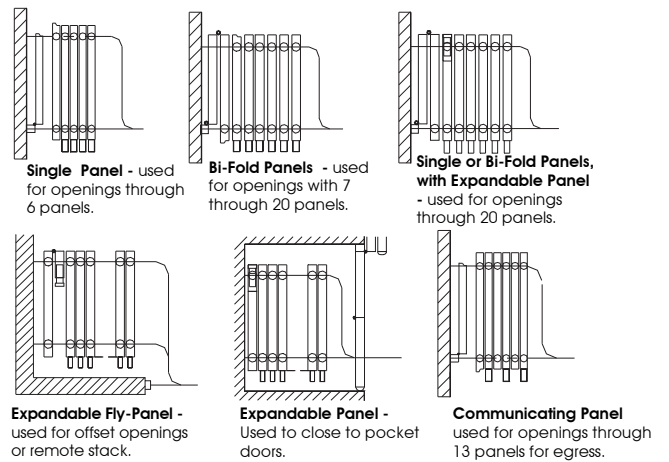

OPTIONS AND ACCESSORIES

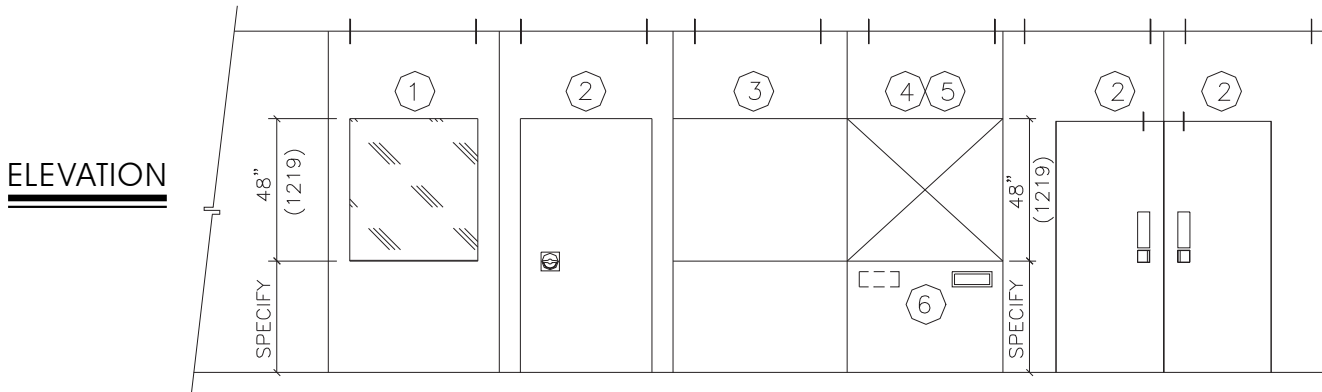

OPTIONS SPECIFICATIONS
 See page 6 for Product Specifications

- ① WINDOWS where indicated on the plans shall be nominally (specify: 48" [1219] high; or full panel height). Windows shall be (specify: factory glazed with 1/4" (6) clear acrylic; or unglazed, framed opening only). Windows shall be bronze trimmed.
- ② SINGLE PASS DOORS where indicated shall be nominally (specify: 3'0" [914]; or 2'8" [813]) wide by (specify: 6'8" [2032]; or 7'0" [2134]) high. Doors shall be manufactured of the same materials and thickness as the panels and be equipped with butt-type hinges and positive latches with drop cup and ring pulls. Double doors have roller latches. Options: deadbolt locks; self illuminated exit signs; hydraulic door closers; A.D.A. compliant friction roller latch with flush pulls.
- ③ TACKBOARDS where indicated shall be nominally (specify: 48" [1219] high; or full panel height). Tackboards shall consist of 1/4" (6) cork surfaced with minimum 30oz per lineal yard Type II Fabrictex vinyl fabric (color to be selected from manufacturer's standards) and bronze trimmed.
- ④ CHALKBOARDS where indicated shall be nominally (specify: 48" [1219] high; or full panel height). Chalkboards shall be chalkable porcelain enameled steel (color to be selected from manufacturer's standards) and bronze trimmed.
- ⑤ MARKERBOARDS where indicated shall be nominally (specify: 48" [1219] high; or full panel height) and be of suitable non-porous surfaced porcelain enameled steel for application of write-on, wipe-off marker pens. Color of markerboards to be selected from manufacturer's standards and bronze trimmed.
- ⑥ RECESSED TRAY for storing chalk or marking pens and erasers shall be installed where indicated and shall be bronze color.

FURTHER INFORMATION. All dimensions shown in parentheses are millimeters. **Moduflex Series 600** operable walls have four inch thick panels for high performance applications and are supplied with Autoseal™ clearance type bottom seal mechanisms that are actuated automatically by moving one panel against the other. Optional Manuseal™ available. Scale N.T.S.



Moduflex® SERIES 600

Individual Panels Model 610 PP

TYPES OF CLOSURES AND PANEL STACKING

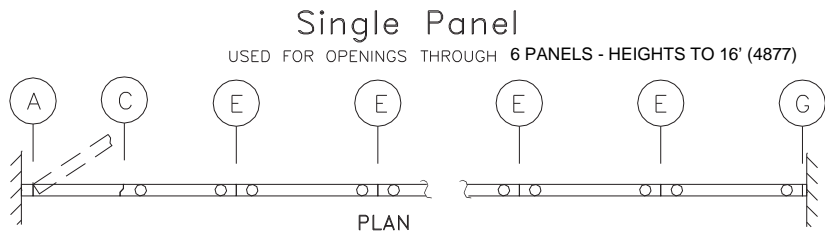
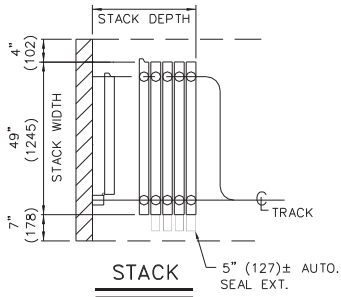

$$\text{STACK DEPTH} = \text{NO. PANELS} \times 4.625" (117) \text{ PLUS } 3 \frac{1}{2}" (89)$$

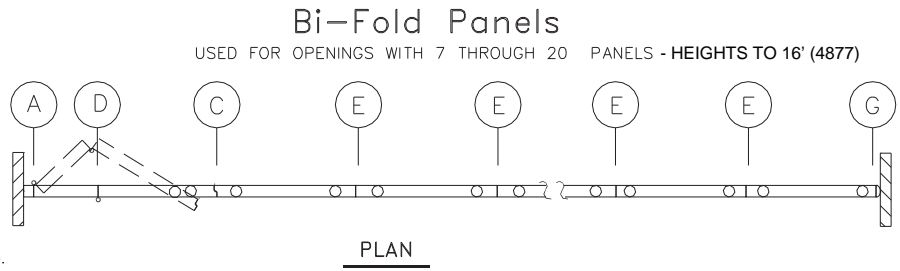
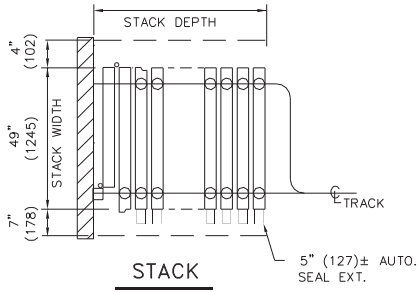

$$\text{STACK DEPTH} = \text{NO. PANELS} \times 4.625" (117) \text{ PLUS } 3 \frac{1}{2}" (89)$$

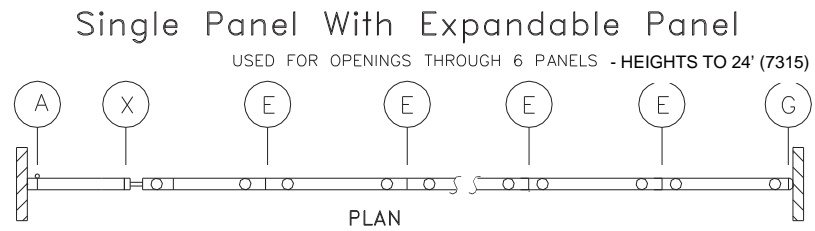
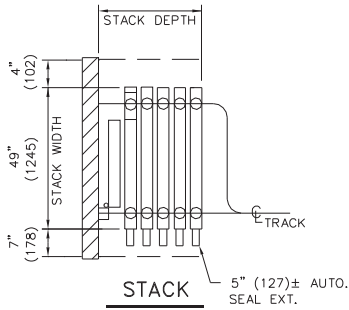

$$\text{STACK DEPTH} = \text{NO. PANELS} \times 4.625" (117) \text{ PLUS } 3 \frac{1}{2}" (89)$$

FOR HEIGHTS OVER 16' (4877), ADD 16" (808) FOR ANGLE STACK

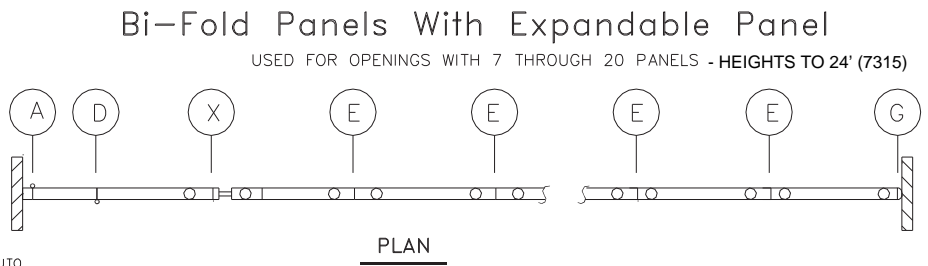
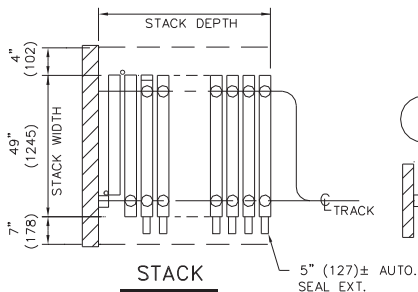

$$\text{STACK DEPTH} = \text{NO. PANELS} \times 4.625" (117) \text{ PLUS } 3 \frac{1}{2}" (89)$$

FOR HEIGHTS OVER 16' (4877), ADD 16" (808) FOR ANGLE STACK



Moduflex® SERIES 600
Individual Panels Model 610 PP

TYPES OF CLOSURES AND PANEL STACKING

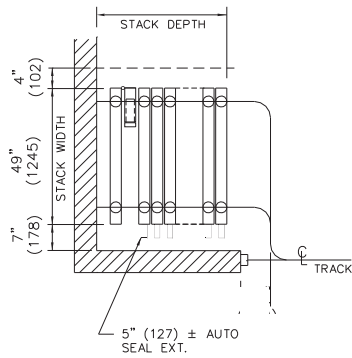

STACK

Expandable Fly Panel

USED FOR OFF-SET OPENINGS - HEIGHTS TO 24' (7315)

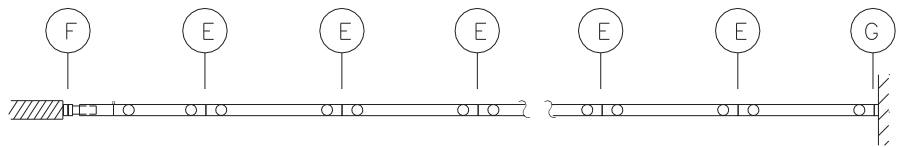

PLAN

STACK DEPTH = NO. PANELS X 3.625" (92)
FOR HEIGHTS OVER 16' (4877), ADD 16" (808) FOR ANGLE STACK

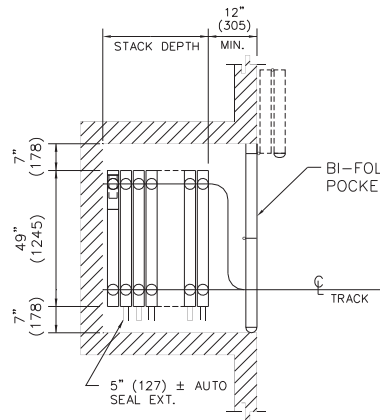

STACK

Expandable Panel

USED TO CLOSE TO POCKET DOOR - HEIGHTS TO 24' (7315)

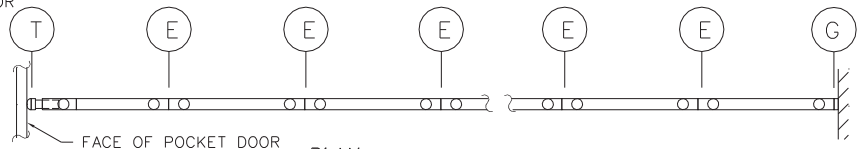

PLAN

STACK DEPTH = NO. PANELS X 3.625" (92)
FOR HEIGHTS OVER 16' (4877), ADD 16" (808) FOR ANGLE STACK

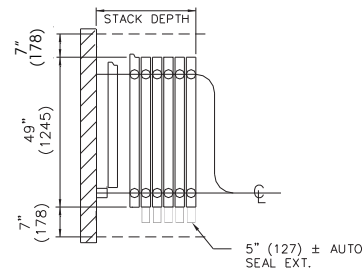

STACK

Communicating Panel

USED FOR OPENINGS THROUGH 13 PANELS - HEIGHTS TO 16" (4877)

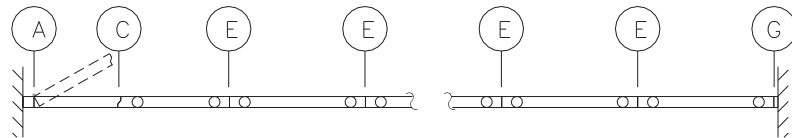

PLAN

STACK DEPTH = NO. PANELS X 3.625" (92) PLUS 3 1/2" (89)

Moduflex SERIES 600

Individual Panels Model 610 PP

JAMBS AND PANEL INTERLOCKING DETAILS

N.P.W. = NOMINAL PANEL WIDTH

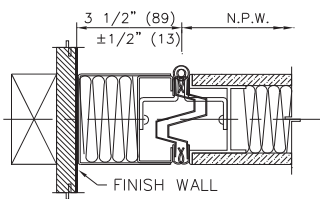

(A) ADJ. HINGED JAMB

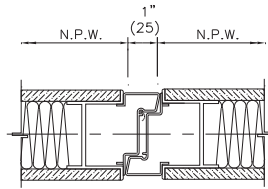

(C) CLOSURE DETAIL

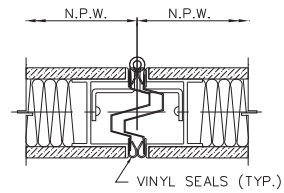

(D) HINGED INTERLOCK

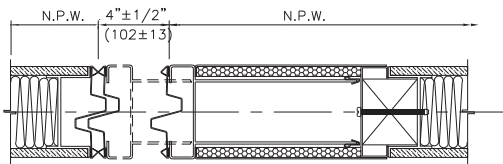

(X) EXPANDABLE PANEL WITH INTERLOCK

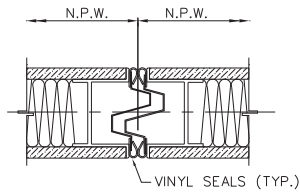

(E) INTERLOCK

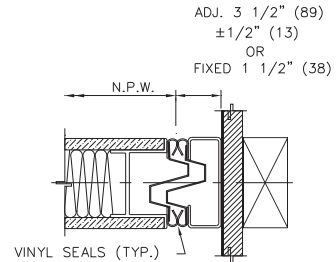

(G) LEAD JAMB

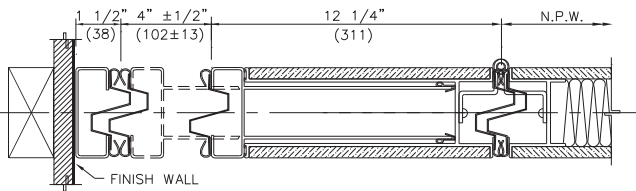

(F) EXPANDABLE FLY PANEL WITH INTERLOCK AT JAMB

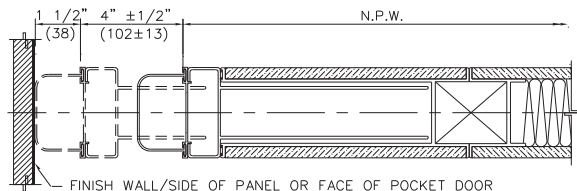

(T) EXPANDABLE PANEL WITH SOFT SEAL



Moduflex® SERIES 600

Individual Panels Model 610 PP

VERTICAL SECTION - HEAD DETAILS - TYPE 7/8 ALUMINUM TRACK

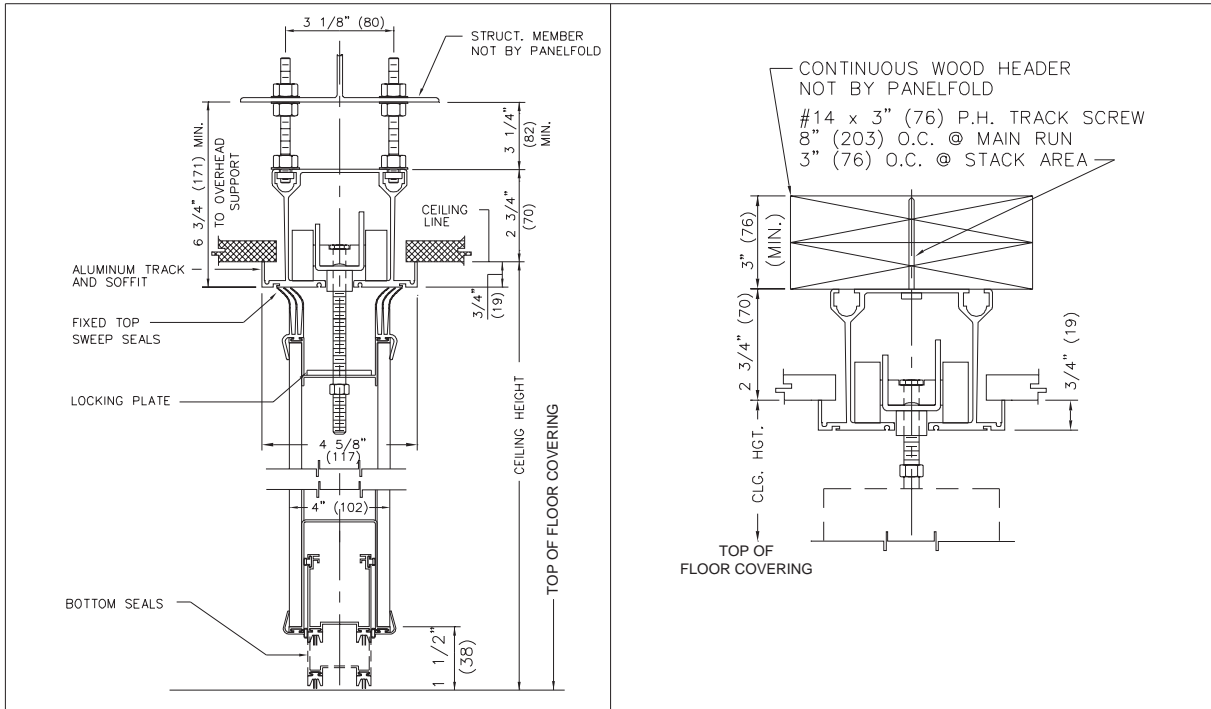

TYPE 7/8 TRACK
HANGER ROD SUSPENSION

TYPE 7/8 TRACK
DIRECT MOUNT

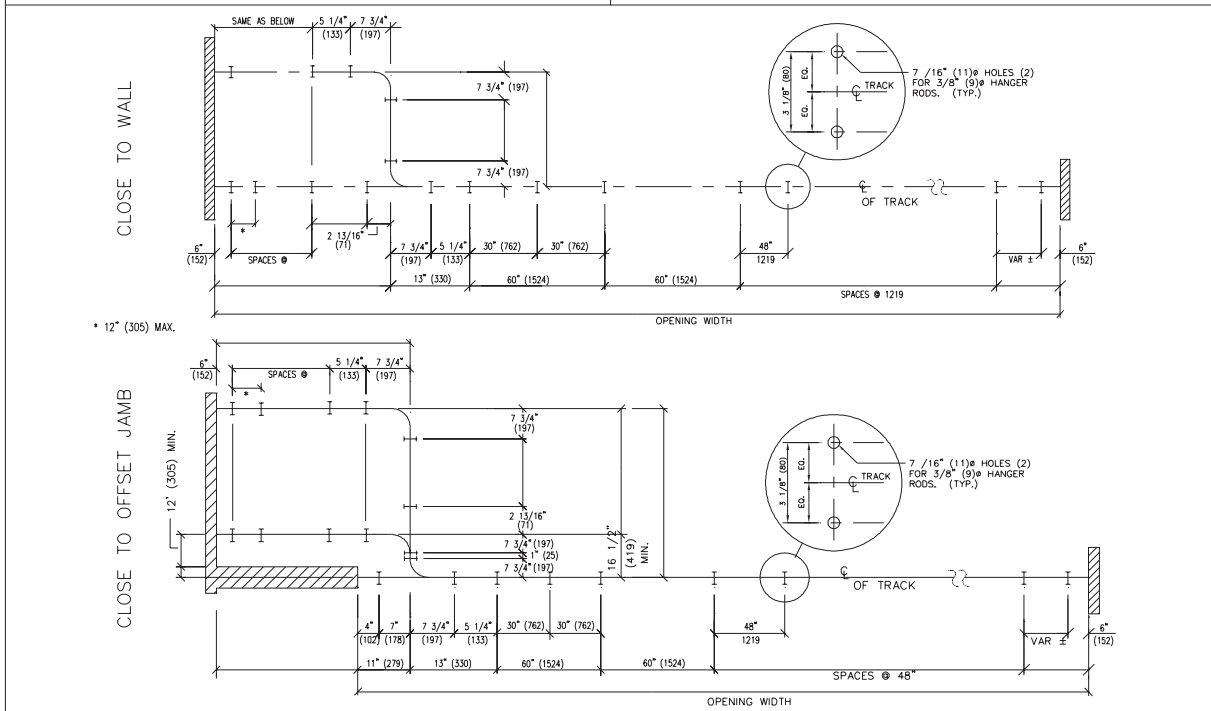

PUNCHING TEMPLATE

All dimensions shown in parentheses are millimeters. Scale: N.T.S.

Moduflex® SERIES 600

Individual Panels Model 610PP (Pre-Programmed)

PRODUCT SPECIFICATIONS: SECTION 10650 - OPERABLE WALLS

PART 1 GENERAL

(See Project Guide Specifications for Scope, Related Work, References, Submittals, Product Delivery and Acceptable Manufacturers paragraphs.)

PART 2 PRODUCTS

- 2.1 OPERABLE WALLS** shall be manufactured by Panelfold, Inc., Miami, Florida, U.S.A. and installed by an authorized representative of the manufacturer in openings prepared by others to Moduflex® Series 600 requirements.
- 2.2 OPERATION** shall consist of a series of manually operated flat panels, top supported. Top and bottom seals shall be as specified in paragraph 2.8.
- 2.3 PANEL CONFIGURATION** shall be as follows for areas indicated on the plans:
- 2.3.1 MODEL 610 shall be comprised of a series of pre-programmed, individual panels, side or remote stacking (located in room(s):).
- 2.3.2 Final closure shall be effected by (specify: Jamb-Hinged single or bi-fold Panels; Expandable Panels; or Jamb-Hinged Communicating Panels).
- 2.4 PANELS** shall be 4" (102) thick and nominally 49" (1245) wide. Panel faces shall be laminated to metal frames. Panels shall have appropriate internal insulation to achieve specified STC. The tops of the panels shall be reinforced to support suspension components.
- The vertical edges of the panels shall not require trim thus minimizing the appearance of the vertical joining of the Sheer-Look® panels.
- 2.5 PANELS** shall be factory surfaced with one of the following (colors to be selected from manufacturer's standards):
- 2.5.1 Manufacturer's standard vinyl, Class A flame spread (specify Type I; or Type II).
- 2.5.2 Manufacturer's standard Ribtex®, vertical-rib wall carpeting, Class A, minimum weight 33 oz. per lineal yard, latex backed.
- 2.5.3 Manufacturer's Woventex® panel fabric, Class A, acrylic latex backed.
- 2.5.4 Maharam Tekwall 1000 panel fabric, Class A acrylic backed.
- 2.5.5 Genuine unfinished wood veneer shall be (specify: White Ash, Red Oak, Natural Birch, American Walnut or other species as specified).
- 2.5.6 High pressure plastic laminate, vertical grade.
- 2.5.7 Customer's Own Material to be factory

applied (subject to approval by the manufacturer for suitability to standard manufacturing processes and equipment).

2.5.8 Unsurfaced panel skins for field finishing by others.

2.6 HANGING WEIGHT of panels shall not exceed 10 lbs./ft² (48.8kg/m²).

2.7 ACOUSTICAL RATING as tested by an independent acoustical laboratory in accordance with ASTM E90-81 test procedures in a full scale 14'0" (4267) by 9'3" (2819) opening shall be (specify: STC 50, STC 47, or STC 45).

2.8 SOUND SEALS shall be as follows:

2.8.1 Vertical seals between panels shall consist of deep nesting, universal interlocking ESP bronze steel astragals incorporating continuous, vinyl acoustical seals. Vertical astragal vinyl seals shall be installed on the outboard edges of the panel skins in a double row with an acoustical labyrinth.

2.8.2 Horizontal TOP seals shall be (specify: continuous contact extruded vinyl shapes; or clearance type, automatically actuated; or clearance type, manually actuated).

2.8.3 Horizontal BOTTOM seals shall be (specify: 1 1/2" (38) clearance-type automatically actuated by the movement of one panel-pair against the other; or 1 1/2" (38) clearance-type manually actuated at waist height on panel edges). Downward pressure of all clearance-type seal mechanisms shall assure an acoustical seal and resist panel movement.

2.9 SUSPENSION SYSTEM shall be heavy duty aluminum Type 7/8 track. Track shall be supported by (specify: adjustable steel hanger rods; or direct mount). Panels shall be supported by trolley assemblies of radial type nylon tired or carbon fiber fill tired, steel ball-bearing wheels. Trolleys shall be attached to the panels with adjustable steel pendant bolts with locks to prevent panel misalignment.

2.10 PANELS that are hinged together shall be hinged with manufacturer's standard butt-type hinges.

2.11 POCKET DOORS where indicated on the plans shall be manufactured of the same materials as the panels. Hinges shall be standard butt-type.

PART 3 EXECUTION

(See Project Specifications Guide for Execution, Installation, Cleaning and Demonstration paragraphs).

NOTE: The ASTM - 84 procedure Class A flame spread and other test results referenced herein are for comparison purposes only and are not intended to reflect hazards presented by this or any other materials under actual fire conditions.

For further information, or additional technical information, contact your Panelfold distributor.

Panelfold®

FOLDING DOORS • ACOUSTICAL FOLDING PARTITIONS
OPERABLE WALLS • RELOCATABLE WALLS

Panelfold, Inc. P.O. Box 680130, Miami, Florida 33168
(305) 688-3501 • FAX: (305) 688-0185