

OPERABLE WALLS  
**Panelfold®**  
**Moduflex®**  
 SERIES 600  
 Paired Panels  
 Model 620

PRODUCT BRIEF

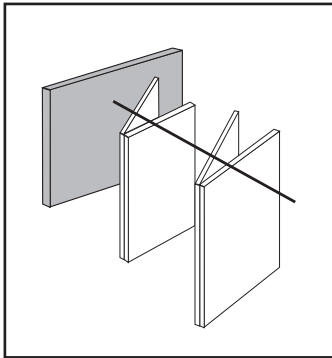

**OPERATING FEATURES.**  
**Moduflex Model 620** panels, hinged in groups of two, each top supported by a truck of four radial type, steel ball-bearing wheels, may be conveniently manually operated and "center" stacked. Heights to 16'0" (4877).

**ACOUSTICAL PERFORMANCE.**  
**Moduflex Series 600** operable walls have attained ratings of STC 50, STC 47, and STC 45.

**PANEL FINISHES.** A full range of vinyl, panel fabric, wood veneers, high pressure laminates and wall carpet as well as Customer's Own Materials is offered.

TYPES OF CLOSURES

See pages 2,3 and 4 for details.

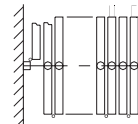

**Single Panel** used with odd numbered panel openings.

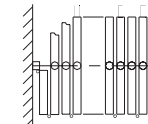

**Bi-Fold Panels** used with even numbered panel openings.

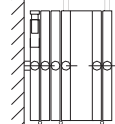

**Expandable Panel - Seal to Wall** used with even numbered panel openings.

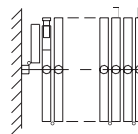

**Single Panel With Expandable Panel -** used with odd numbered panel openings.

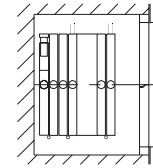

**Expandable Panel - Seal to Pocket Door** used with even numbered panel openings.

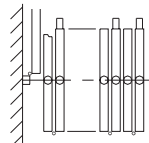

**Communicating Panel** used with odd numbered panel openings for egress.

OPTIONS AND ACCESSORIES

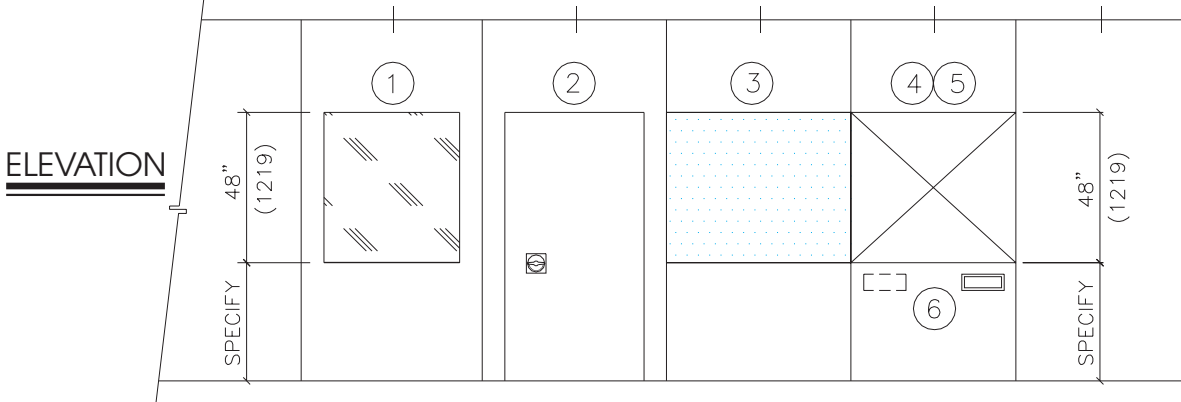

OPTIONS SPECIFICATIONS

See page 6 for Product Specifications

- ① WINDOWS where indicated on the plans shall be nominally (specify: 48" (1219) high; or full panel height). Windows shall be (specify: factory glazed with 1/4" (6) clear acrylic; or unglazed, framed opening only). Windows shall be bronze trimmed.
- ② SINGLE PASS DOORS where indicated shall be nominally (specify: 3'0" (914); or 2'8" (813)) wide by (specify: 6'8" (2032); or 7'0" (2134)) high. Doors shall be manufactured of the same materials and thickness as the panels and be equipped with butt-type hinges and positive latches with drop cup and ring pulls. Options: dead-bolt locks; self illuminated exit signs; hydraulic door closers; A.D.A. compliant friction roller latch with flush pulls.
- ③ TACKBOARDS where indicated shall be nominally (specify: 48" (1219) high; or full panel height). Tackboards shall consist of 1/4" (6) cork surfaced with minimum 30oz per lineal yard Type II

- Fabricex vinyl fabric (color to be selected from manufacturer's standards) and bronze trimmed.
- ④ CHALKBOARDS where indicated shall be nominally (specify: 48" (1219) high; or full panel height). Chalkboards shall be chalkable porcelain enameled steel (color to be selected from manufacturer's standards) and bronze trimmed.
- ⑤ MARKERBOARDS where indicated shall be nominally (specify: 48" (1219) high; or full panel height) and be of suitable non-porous surfaced porcelain enameled steel for application of write-on, wipe-off marker pens. Color of markerboards to be selected from manufacturer's standards and bronze trimmed.
- ⑥ RECESSED TRAY for storing chalk or marking pens and erasers shall be installed where indicated and shall be bronze color.

FURTHER INFORMATION. All dimensions shown in parentheses are millimeters. **Moduflex Series 600** operable walls have four inch thick panels for high performance applications and are supplied with Autoseal™ clearance type bottom seal mechanisms that are actuated automatically by moving one panel pair against the other. Optional Manuseal™ available. Scale N.T.S.



# Moduflex® SERIES 600

## Paired Panels Model 620

### TYPES OF CLOSURES AND PANEL STACKING

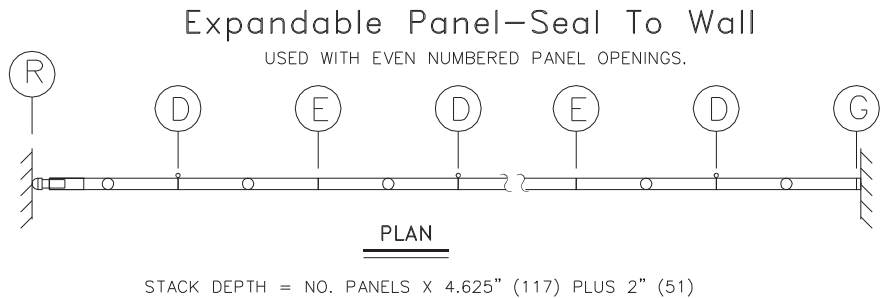
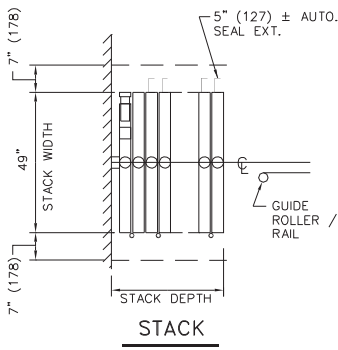
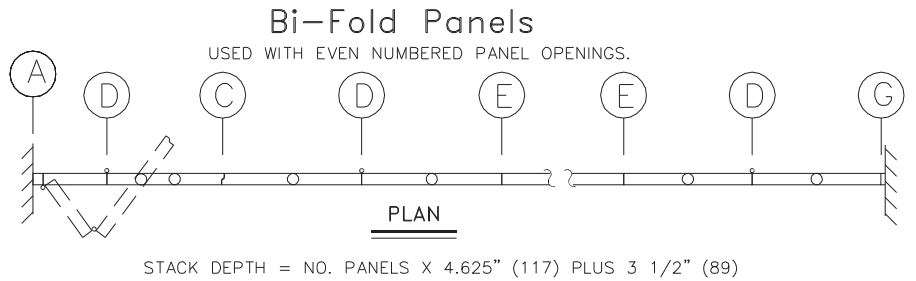
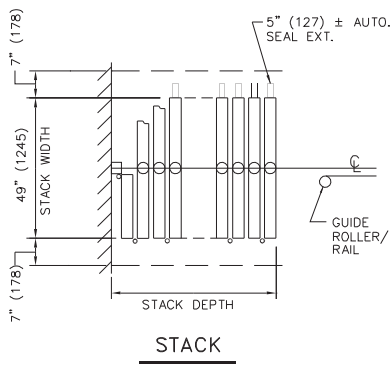
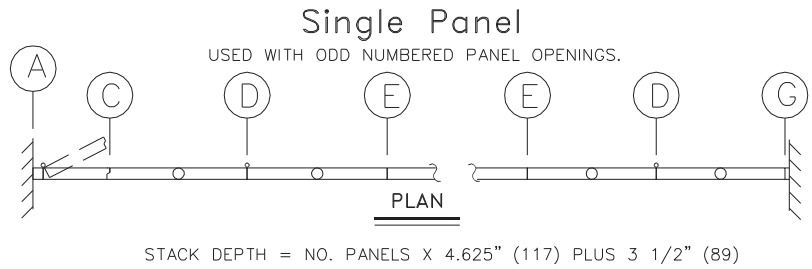
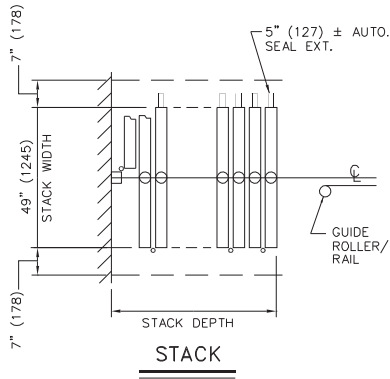



# Moduflex® SERIES 600

## Paired Panels Model 620

### TYPES OF CLOSURES AND PANEL STACKING

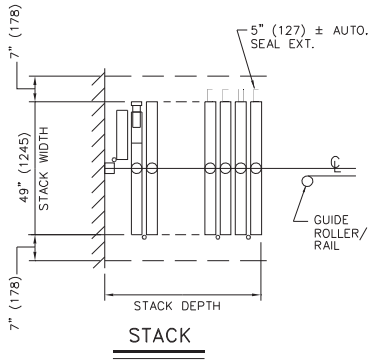

#### Single Panel With Expandable Panel

USED WITH ODD NUMBERED PANEL OPENINGS.

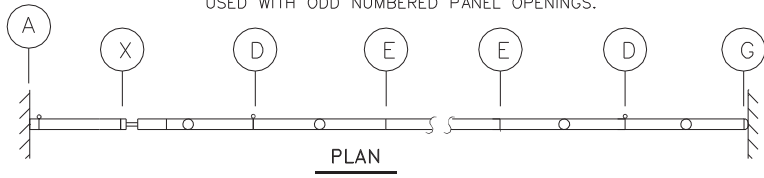

$$\text{STACK DEPTH} = \text{NO. PANELS} \times 4.625" (117) \text{ PLUS } 3 \frac{1}{2}" (89)$$

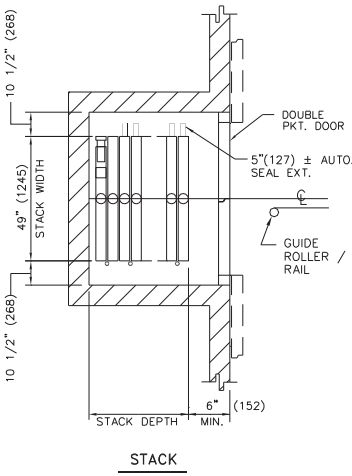

#### Expandable Panel – Seal To Pocket Doors

USED WITH EVEN NUMBERED PANEL OPENINGS.

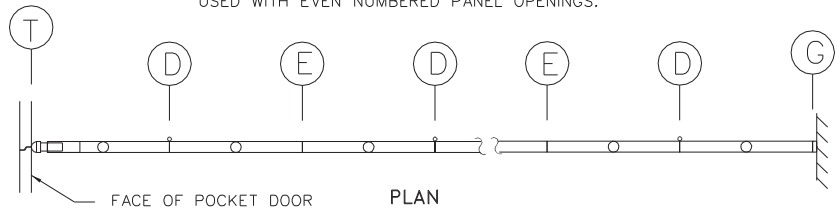

$$\text{STACK DEPTH} = \text{NO. PANELS} \times 4.625" (117)$$

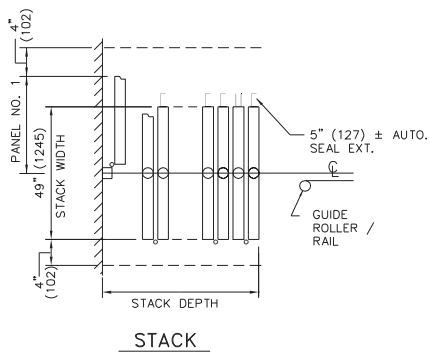

#### Communicating Panel

USED WITH ODD NUMBERED PANEL OPENINGS.

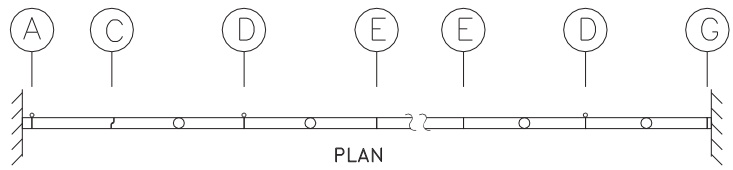

$$\text{STACK DEPTH} = \text{NO. PANELS} \times 4.625" (117) \text{ PLUS } 3 \frac{1}{2}" (89)$$



**Moduflex SERIES 600**  
Paired Panels Model 620

JAMBS AND PANEL INTERLOCKING DETAILS

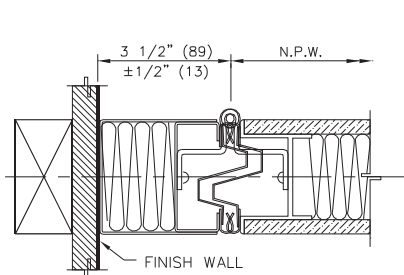

(A) ADJ. HINGED JAMB

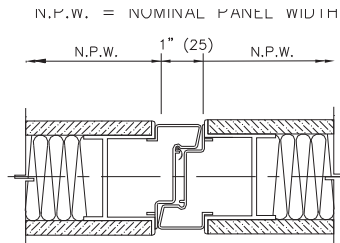

(C) CLOSURE DETAIL

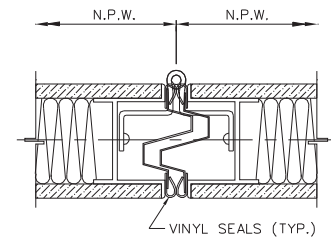

(D) HINGED INTERLOCK

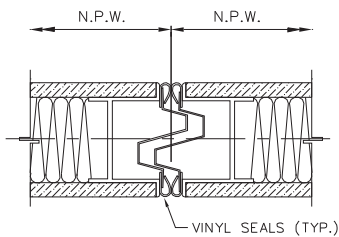

(E) INTERLOCK

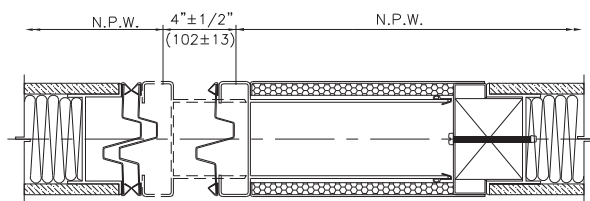

(X) EXPANDABLE PANEL WITH INTERLOCK

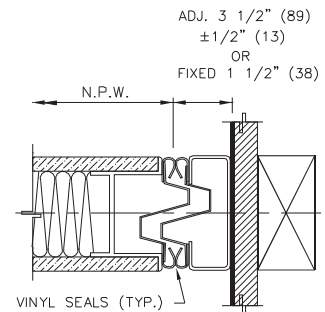

(G) LEAD JAMB

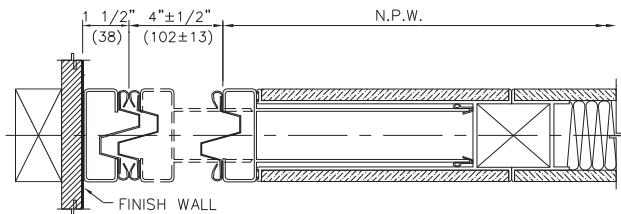

(R) EXPANDABLE PANEL WITH INTERLOCK AT JAMB

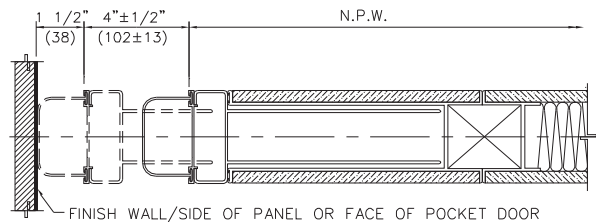

(T) EXPANDABLE PANEL WITH SOFT SEAL

All dimensions shown in parentheses are millimeters. Scale: N.T.S.



**Moduflex® SERIES 600**  
Paired Panels Model 620

VERTICAL SECTION - HEAD DETAILS - TYPE 7/8 ALUMINUM TRACK

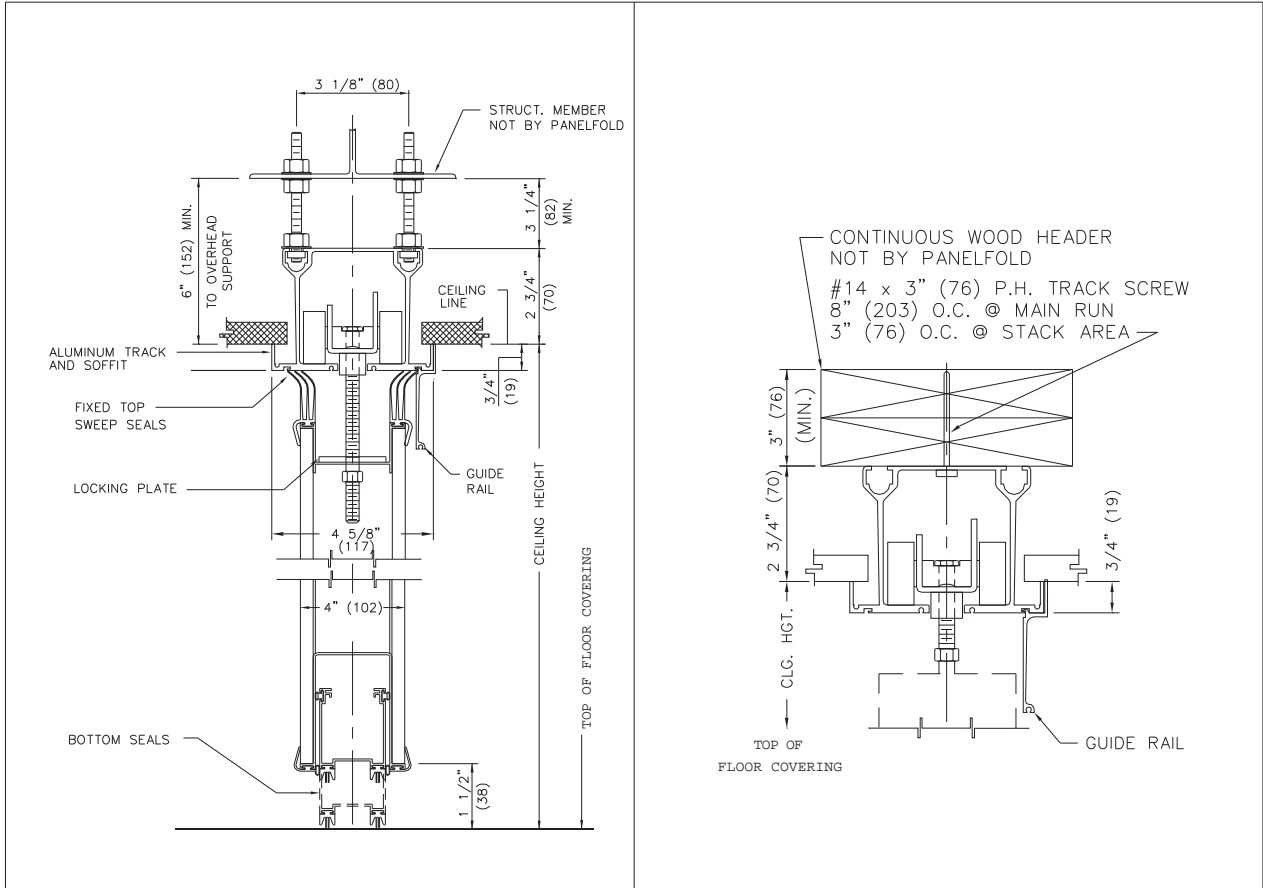

TYPE 7/8 TRACK  
HANGER ROD SUSPENSION

TYPE 7/8 TRACK  
DIRECT MOUNT

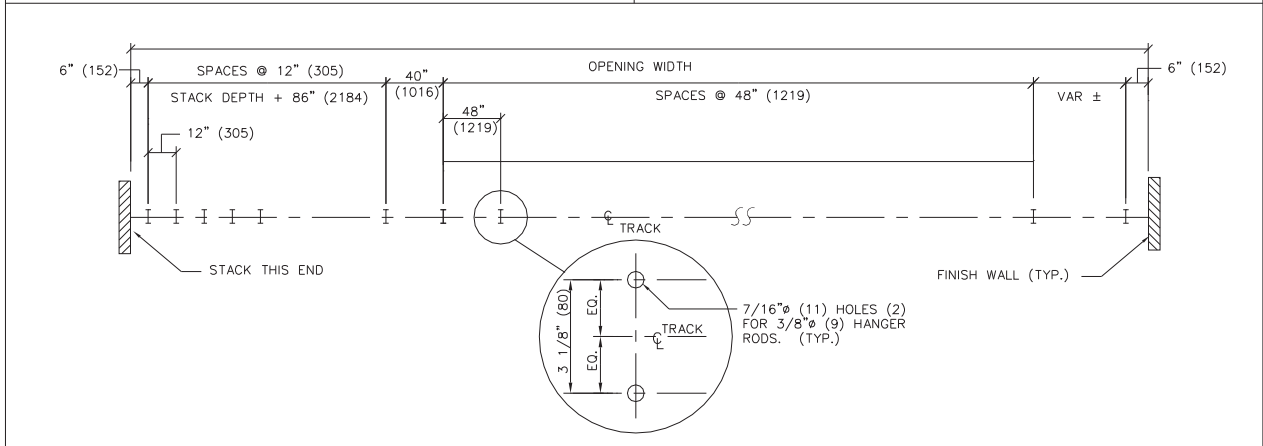

PUNCHING TEMPLATE

All dimensions shown in parentheses are millimeters. Scale: N.T.S.

## Moduflex® SERIES 600 Paired Panels Model 620

### PRODUCT SPECIFICATIONS: SECTION 10650 - OPERABLE WALLS

#### PART 1 GENERAL

(See Project Guide Specifications for Scope, Related Work, References, Submittals, Product Delivery and Acceptable Manufacturers paragraphs.)

#### PART 2 PRODUCTS

**2.1 OPERABLE WALLS** shall be manufactured by Panelfold, Inc., Miami, Florida, U.S.A. and installed by an authorized representative of the manufacturer in openings prepared by others to Moduflex® Series 600 requirements.

**2.2 OPERATION** shall consist of a series of manually operated flat panels, top supported. Top and bottom seals shall be as specified in paragraph 2.8.

**2.3 PANEL CONFIGURATION** shall be as follows for areas indicated on the plans:

2.3.1 MODEL 620 shall be comprised of panels hinged in pairs, and center stacking (located in room(s)).

2.3.2 Final closure shall be effected by (specify: Single or Bi-fold Panels; Expandable Panels; or Jamb-Hinged Communicating Panels).

**2.4 PANELS** shall be 4" (102) thick and nominally 49" (1245) wide. Panel faces shall be laminated to metal frames. Panels shall have appropriate internal insulation to achieve specified STC. The tops of the panels shall be reinforced to support suspension components.

The vertical edges of the panels shall not require trim thus minimizing the appearance of the vertical joining of the Sheer-Look® panels.

**2.5 PANELS** shall be factory surfaced with one of the following (colors to be selected from manufacturer's standards):

2.5.1 Manufacturer's standard vinyl, Class A

flame spread (specify Type I; or Type II).

2.5.2 Manufacturer's standard Ribtex® Basic, vertical-rib wall carpeting, Class A.

2.5.3 Manufacturer's Woventex® panel fabric, Class A, acrylic latex backed.

2.5.4 Maharam Tekwall panel fabric, Class A acrylic backed.

2.5.5 Genuine unfinished wood veneer shall be (specify: White Ash, Red Oak, Natural Birch, American Walnut or other species as specified).

2.5.6 High pressure laminate, vertical grade.

2.5.7 Customer's Own Material to be factory applied (subject to approval by the

manufacturer for suitability to standard manufacturing processes and equipment).

2.5.8 Unsurfaced panel skins for field finishing by others.

**2.6 HANGING WEIGHT** of panels shall not exceed 10 lbs./ft² (48.8 Kg./m²).

**2.7 ACOUSTICAL RATING** as tested by an independent acoustical laboratory in accordance with ASTM E90-81 test procedures in a full scale 14'0" (4267) by 9'3" (2819) opening shall be (specify: STC 50, STC 47, or STC 45).

**2.8 SOUND SEALS** shall be as follows:

2.8.1 Vertical seals between panels shall consist of deep nesting, universal interlocking ESP bronze steel astragals incorporating continuous, vinyl acoustical seals. Vertical astragal vinyl seals shall be installed on the outboard edges of the panel skins in a double row with an acoustical labyrinth.

2.8.2 Horizontal TOP seals shall be (specify: continuous contact extruded vinyl shapes; or clearance type, manually actuated; or clearance type, automatically actuated).

2.8.3 Horizontal BOTTOM seals shall be (specify: 1 1/2" (38) clearance-type automatically actuated by the movement of one panel-pair against the other; or 1 1/2" (38) clearance-type manually actuated at waist height on panel edges). Downward pressure of all clearance-type seal mechanisms shall assure an acoustical seal and resist panel movement.

**2.9 SUSPENSION SYSTEM** shall be heavy duty aluminum Type 7/8 track. Track shall be supported by (specify: adjustable steel hanger rods; or direct mount). Panels shall be supported by trolley assemblies of radial type nylon tired or carbon fiber fill tired, steel ball-bearing wheels. Trolleys shall be attached to the panels with adjustable steel pendant bolts with locks to prevent panel misalignment.

**2.10 PANELS** that are hinged together shall be hinged with manufacturer's standard butt-type hinges.

**2.11 POCKET DOORS** where indicated on the plans shall be manufactured of the same materials as the panels. Hinges shall be standard butt-type.

#### PART 3 EXECUTION

(See Project Guide Specifications for Execution, Installation, Cleaning and Demonstration paragraphs).

**NOTE:** The ASTM - 84 procedure Class A flame spread and other test results referenced herein are for comparison purposes only and are not intended to reflect hazards presented by this or any other materials under actual fire conditions.

For further information, or additional technical information, contact your Panelfold distributor.

**Panelfold®**

FOLDING DOORS • ACOUSTICAL FOLDING PARTITIONS • ACOUSTICAL PANELS  
OPERABLE WALLS • RELOCATABLE WALLS

Panelfold, Inc. P.O. Box 680130, Miami, Florida 33168  
(305) 688-3501 • FAX: (305) 688-0185

Internet: www.panelfold.com • E-mail: sales@panelfold.com