

OPERABLE WALLS
Panelfold®
Moduflex®
 SERIES 600
 Continuously Hinged Panels
 Model 640
 Electrically Operated

PRODUCT BRIEF

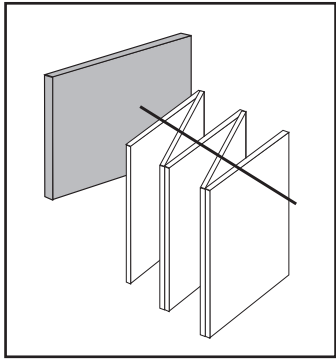

OPERATING FEATURES.
Moduflex Model 640 continuously-hinged panels, top supported on alternate panels by radial type, steel ball-bearing wheels, are electrically chain driven and "center" stacked. Heights to 24' (7315).

ACOUSTICAL PERFORMANCE.
Moduflex Series 600 operable walls have attained ratings of STC 50, STC 47 and STC 45.

PANEL FINISHES. A full range of vinyl, panel fabric, wood veneers, high pressure laminates and wall carpet as well as Customer's Own Material is offered.

TYPES OF CLOSURES
 See pages 2,3 and 4 for details.

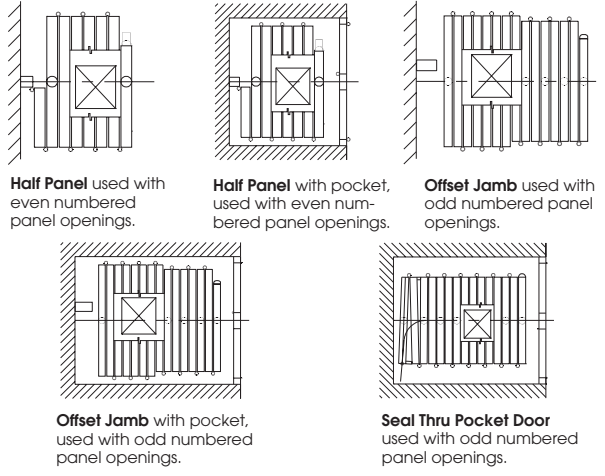

OPTIONS AND ACCESSORIES

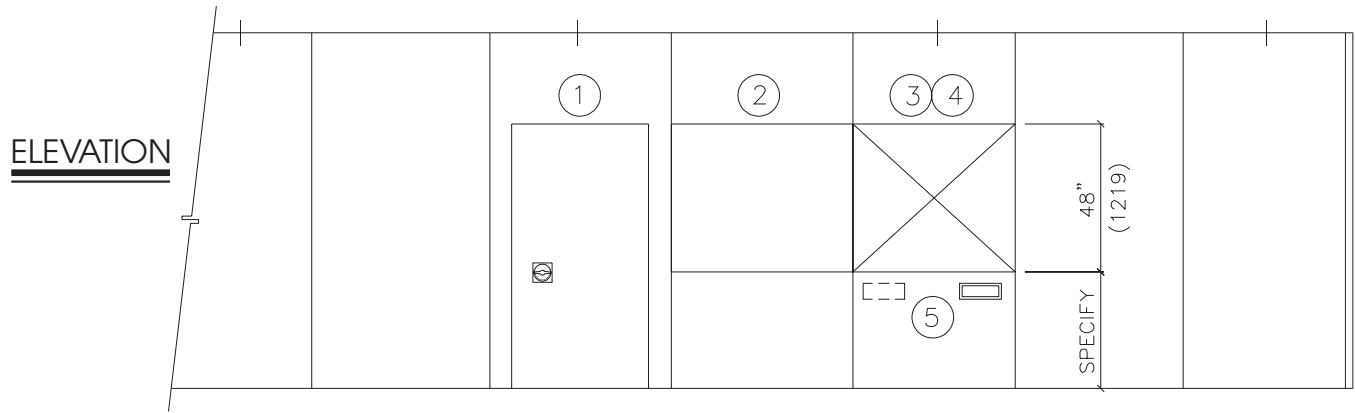

OPTIONS SPECIFICATIONS
 See page 6 for Product Specifications

- ① SINGLE PASS DOORS where indicated shall be nominally (specify: 3'0" (914); or 2'8" (813)) wide by (specify: 6'8" (2032); or 7'0" (2134)) high. Doors shall be manufactured of the same materials and thickness as the panels and be equipped with butt-type hinges and positive latches with drop cup and ring pulls. Options: deadbolt locks; self illuminated exit signs; hydraulic door closers; A.D.A. compliant friction roller latch with flush pulls.
- ② TACKBOARDS where indicated shall be nominally (specify: 48" (1219)) high; or full panel height). Tackboards shall consist of 1/4" (6) cork surfaced with minimum 30oz per lineal yard Type II Fabrictex vinyl fabric (color to be selected from manufacturer's standards) and bronze trimmed.
- ③ CHALKBOARDS where indicated shall be nominally (specify: 48" (1219) high; or full panel height). Chalkboards shall be chalkable porcelain enameled steel (color to be selected from manufacturer's standards) and bronze trimmed.
- ④ MARKERBOARDS where indicated shall be nominally (specify: 48" (1219) high; or full panel height) and be of suitable non-porous surfaced porcelain enameled steel for application of write-on, wipe-off marker pens. Color of markerboards to be selected from manufacturer's standards and bronze trimmed.
- ⑤ RECESSED TRAY for storing chalk or marking pens and erasers shall be installed where indicated and shall be bronze color.

FURTHER INFORMATION. All dimensions shown in parentheses are millimeters. **Moduflex Series 600** operable walls have four inch thick panels for high performance applications and are supplied with Autoseal™ clearance type bottom seal mechanisms that are actuated automatically by the final closing action of the wall. Scale N.T.S.



Moduflex® SERIES 600

Continuously-Hinged Panels Model 640 Electrically Operated

TYPES OF CLOSURES AND PANEL STACKING

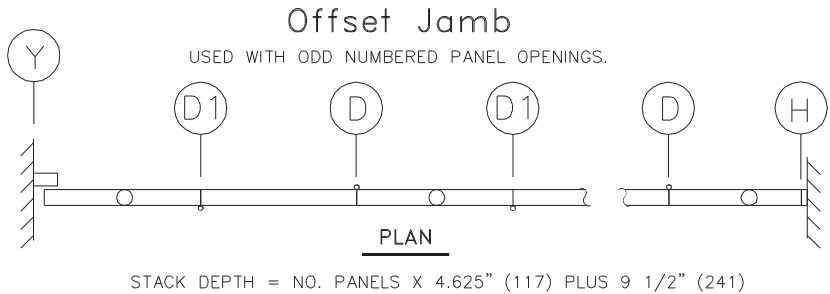
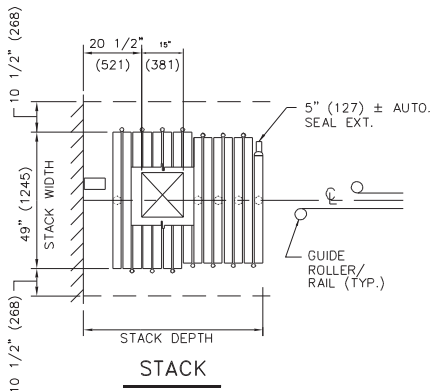
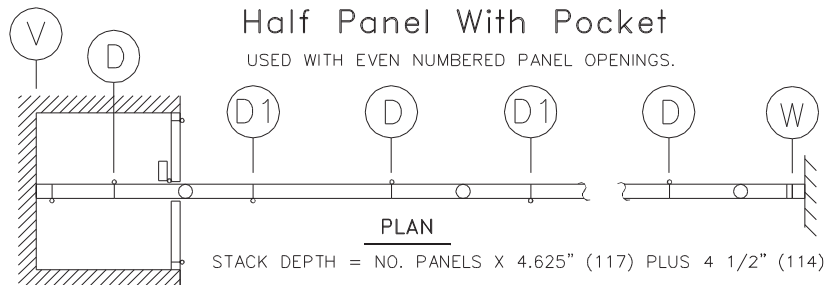
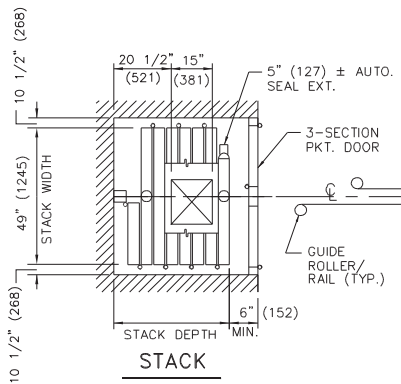
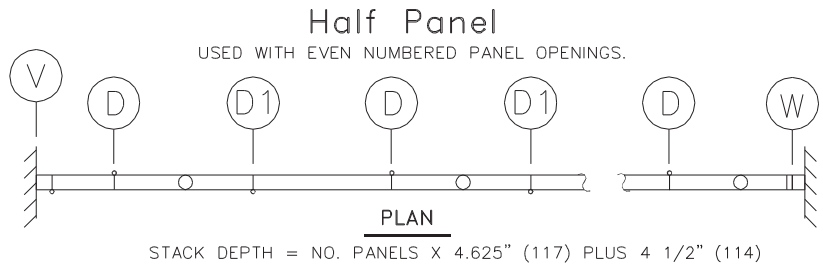
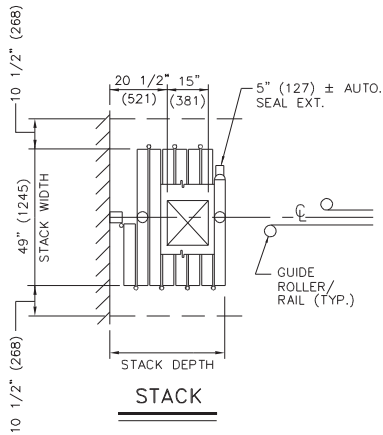



Moduflex® SERIES 600

Continuously-Hinged Panels Model 640 Electrically Operated

TYPES OF CLOSURES AND PANEL STACKING

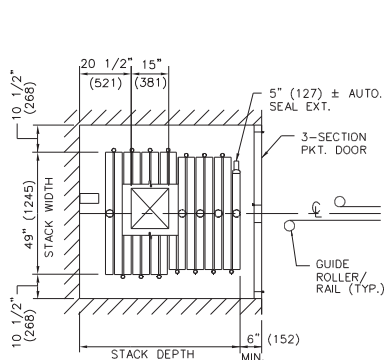

STACK

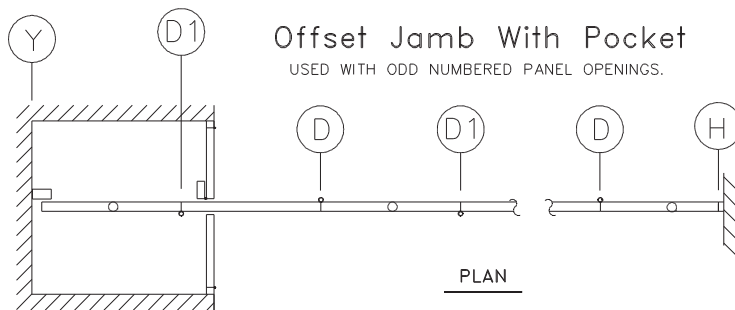

PLAN

STACK DEPTH = NO. PANELS X 4.625" (117) PLUS 9 1/2" (241)

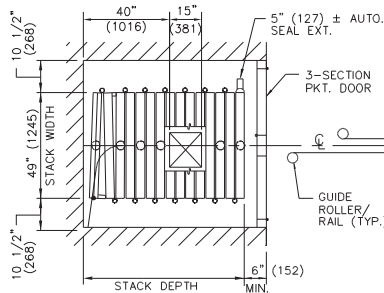

STACK

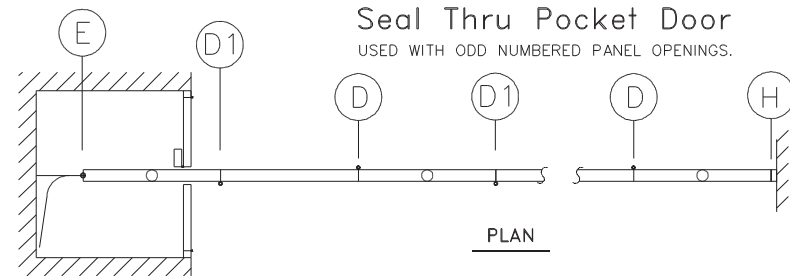

PLAN

STACK DEPTH = NO. PANELS X 4.625" (117) PLUS 6" (152)

PUNCHING TEMPLATE FOR SEAL THRU POCKET DOOR

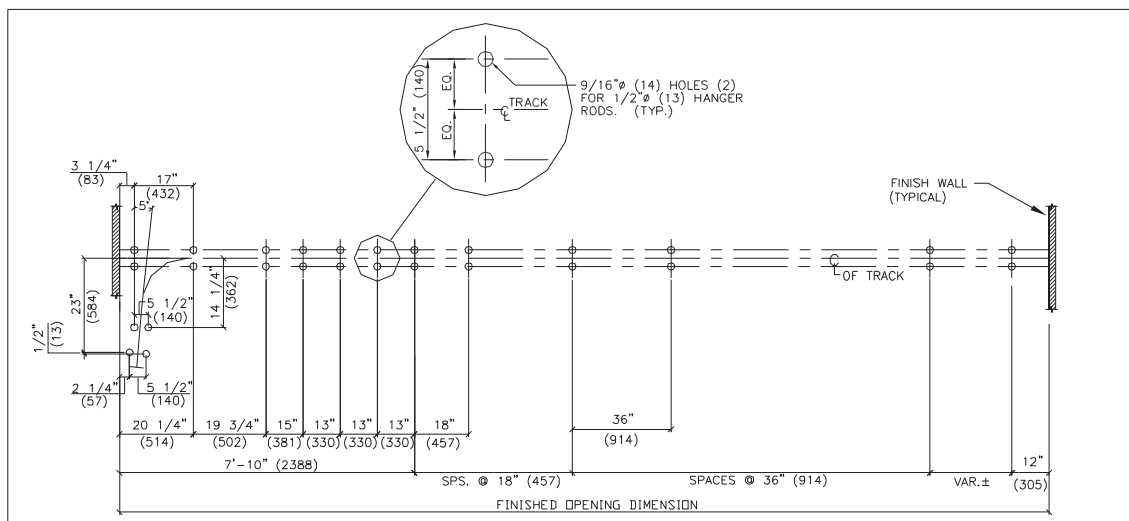

All dimensions shown in parentheses are millimeters. Scale: N.T.S.



Moduflex SERIES 600

Continuously-Hinged Panels Model 640 Electrically Operated

JAMBS AND PANEL INTERLOCKING DETAILS

N.P.W. = NOMINAL PANEL WIDTH

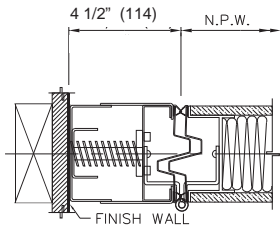

(V) SPRING LOADED JAMB

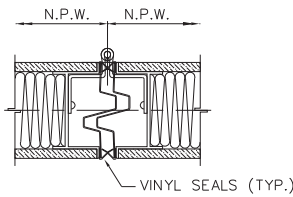

(D) HINGED INTERLOCK

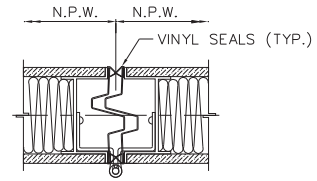

(D1) HINGED INTERLOCK

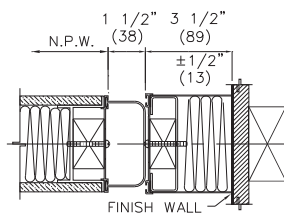

(W) ADJ. JAMB W/ SOFT SEAL

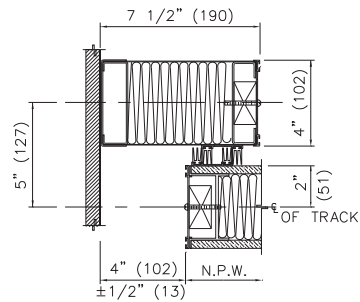

(Y) OFFSET JAMB

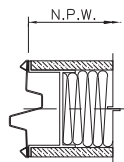

(E) INTERLOCK

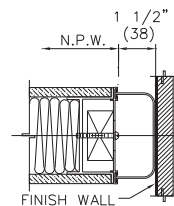

(H) SOFT SEAL

All dimensions shown in parentheses are millimeters. Scale: N.T.S.



Moduflex® SERIES 600

Continuously-Hinged Panels Model 640 Electrically Operated

VERTICAL SECTION - HEAD DETAILS

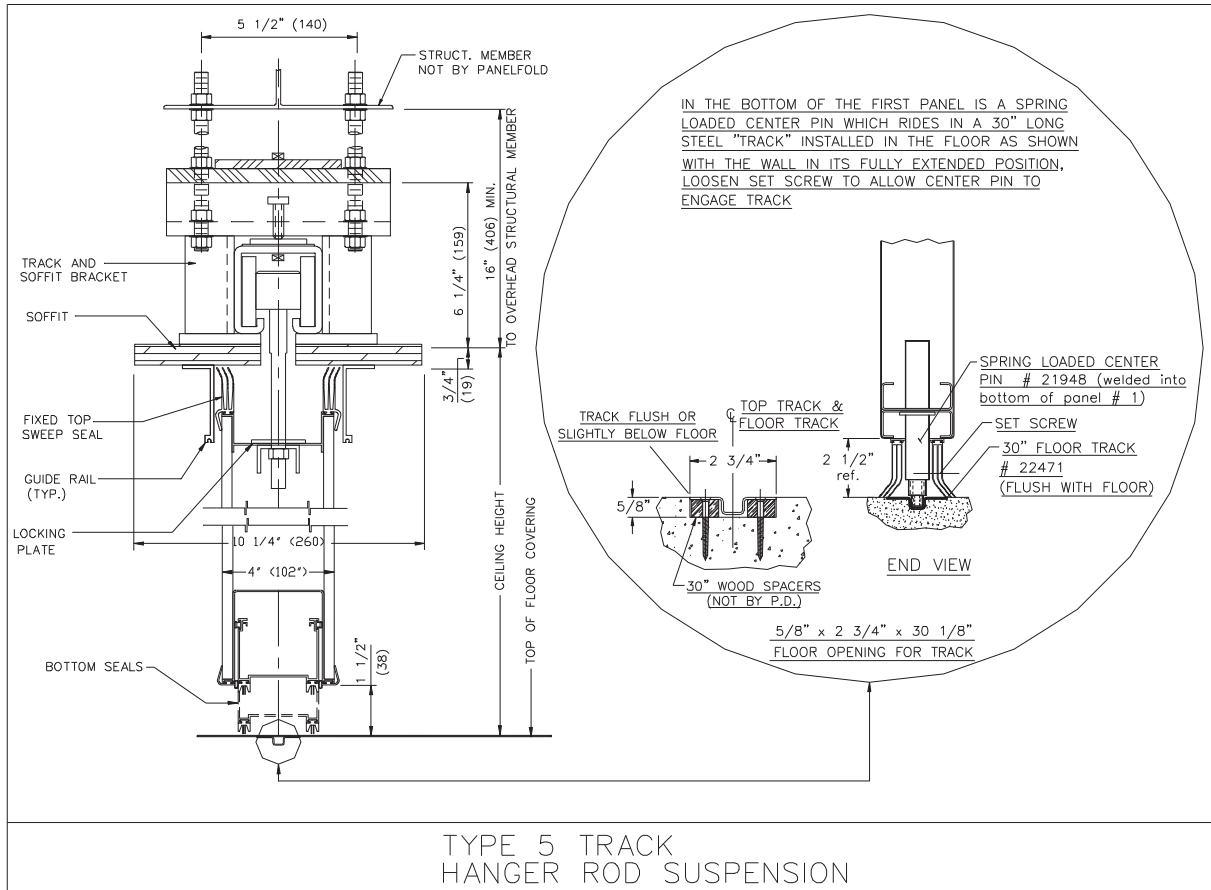

PUNCHING TEMPLATE FOR HALF PANEL AND OFF-SET JAMB CLOSURES

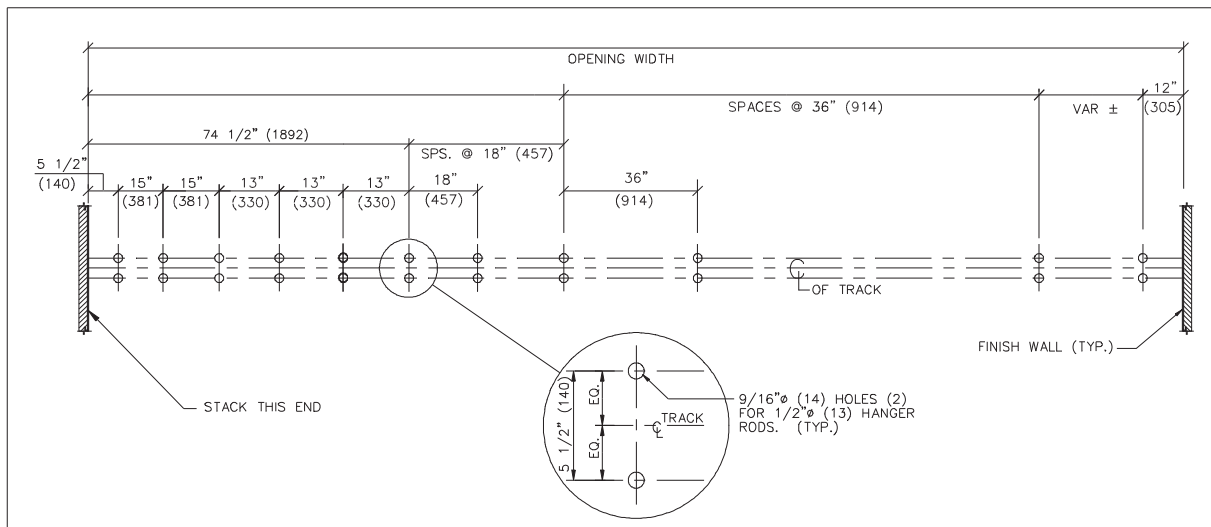

All dimensions shown in parentheses are millimeters. Scale: N.T.S.

Moduflex® SERIES 600

Continuously-Hinged Panels Model 640 Electrically Operated

PRODUCT SPECIFICATIONS: SECTION 10650 - OPERABLE WALLS

PART 1 GENERAL

(See Project Guide Specifications for Scope, Related Work, References, Submittals, Product Delivery and Acceptable Manufacturers paragraphs.)

PART 2 PRODUCTS

2.1 OPERABLE WALLS shall be manufactured by Panelfold, Inc., Miami, Florida, U.S.A. and installed by an authorized representative of the manufacturer in openings prepared by others to Moduflex® Series 600 requirements.

2.2 OPERATION shall consist of a series of electrically operated flat panels, top supported. Top and bottom seals shall be as specified in paragraph 2.8.

2.3 PANEL CONFIGURATION shall be as follows for areas indicated on the plans:

2.3.1 MODEL 640 shall be comprised of a series of continuously-hinged panels, center stacking, electrically operated.

2.3.2 Final closure shall be effected by (specify: Jamb-hinged Half Panels; Offset Jamb; or Seal Thru Pocket Door).

2.4 PANELS shall be 4" (102) thick and nominally 49" (1245) wide. Panel faces shall be laminated to metal frames. Panels shall have appropriate internal insulation to achieve specified STC. The tops of the panels shall be reinforced to support suspension components

The vertical edges of the panels shall not require trim thus minimizing the appearance of the vertical joining of the Sheer-Look® panels.

2.5 PANELS shall be factory surfaced with one of the following (colors to be selected from manufacturer's standards):

2.5.1 Manufacturer's standard vinyl, Class A flame spread (specify: Type I; or Type II).

2.5.2 Manufacturer's standard Ribtex® Basic, vertical-rib wall carpeting, Class A.

2.5.3 Manufacturer's Woventex® panel fabric, Class A, acrylic latex backed.

2.5.4 Maharam Tekwall panel fabric, Class A, acrylic backed.

2.5.5 Genuine unfinished wood veneer shall be (specify: White Ash, Red Oak, Natural Birch, American Walnut or other species as specified).

2.5.6 High pressure laminate, vertical grade.

2.5.7 Customer's Own Material to be factory applied (subject to approval by the manufacturer for suitability to standard manufacturing processes and equipment).

2.5.8 Unsurfaced panel skins for field finishing by others.

2.6 HANGING WEIGHT of panels shall not exceed 10 lbs./ft² (48.8Kg/m²).

2.7 ACOUSTICAL RATING of panels as tested by an independent acoustical laboratory in accordance with ASTM E90-85 test procedures in a full scale 14'0" (4267) by 9'3" (2819) opening shall be (specify: STC 50, STC 47, or STC 45).

2.8 SOUND SEALS shall be as follows:

2.8.1 Vertical seals between panels shall consist of deep nesting, universal interlocking ESP bronze steel astragals incorporating continuous vinyl acoustical seals. Vertical astragal vinyl seals shall be installed on the outboard edges of the panel skins in a double row with an acoustical labyrinth.

2.8.2 Horizontal TOP seals shall be (specify: continuous contact extruded vinyl shapes).

2.8.3 Horizontal BOTTOM seals shall be (specify: 1-1/2" (38) clearance-type automatically actuated; or continuous contact extruded vinyl shapes). Downward pressure of clearance type bottom seal mechanisms shall assure an acoustical seal and resist panel movement.

2.9 SUSPENSION SYSTEM shall be steel Type 5 track. Track hanger brackets shall be supported by adjustable steel hanger rods. Alternate panels shall be supported by trolley assemblies of steel radial type ball-bearing wheels. Trolleys shall be attached to the panels with adjustable steel pendant bolts with locks to prevent panel misalignment.

2.10 PANELS shall be hinged with manufacturer's standard butt-type hinges.

2.11 POCKET DOORS where indicated on the plans shall be manufactured of the same materials as the panels. Hinges shall be standard butt-type.

PART 3 EXECUTION

(See Project Guide Specifications for Execution, Installation, Cleaning and Demonstration paragraphs.)

NOTE: The ASTM - 84 procedure Class A flame spread and other test results referenced herein are for comparison purposes only and are not intended to reflect hazards presented by this or any other materials under actual fire conditions.

For further information, or additional technical information, contact your Panelfold distributor.

Panelfold®

FOLDING DOORS • ACOUSTICAL FOLDING PARTITIONS • ACOUSTICAL PANELS
OPERABLE WALLS • RELOCATABLE WALLS

Panelfold, Inc. P.O. Box 680130, Miami, Florida 33168
(305) 688-3501 • FAX: (305) 688-0185
Internet: www.panelfold.com • E-mail: sales@panelfold.com