

OPERABLE WALLS
Panelfold® Moduflex®
 SERIES 800
 Individual
 Panels

Model
 810 PP
 Pre-
 Programmed

PRODUCT BRIEF

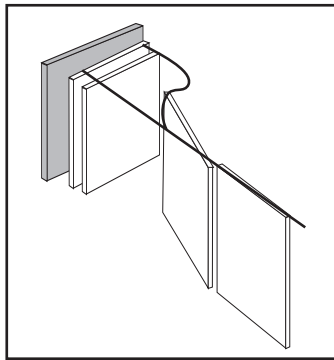

OPERATING FEATURES.
Moduflex Model 810 PP individual panels, top supported by radial type, steel ball-bearing wheels, move one panel at a time and are pre-programmed to make up openings and store the same way every time. Heights to 44' (13411).

ACOUSTICAL PERFORMANCE.
Moduflex Series 800 operable walls have attained ratings of STC 54, STC 52, STC 49, STC 47 and N.R.C. .90 (STC 50).

PANEL FINISHES. A full range of vinyl, panel fabric, and wall carpet as well as Customer's Own Material may be specified.

U.L.® FIRE RATING. Series 800 walls may be specified with one hour rating.

TYPES OF CLOSURES
 See pages 2,3 and 4 for details.

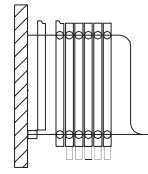

Single Panel used for openings through 6 panels.

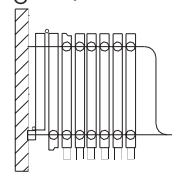

Bi-Fold Panels used for openings with 7 through 20 panels.

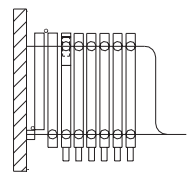

Single or Bi-Fold Panels with Expandable Panel, used for openings through 20 panels.

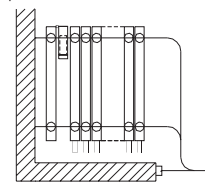

Expandable Fly-Panel. used for offset openings.

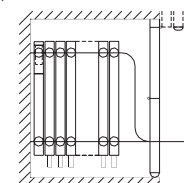

Expandable Panel - used to close to pocket doors.

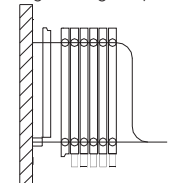

Communicating Panel used for openings through 13 panels for egress.

OPTIONS AND ACCESSORIES

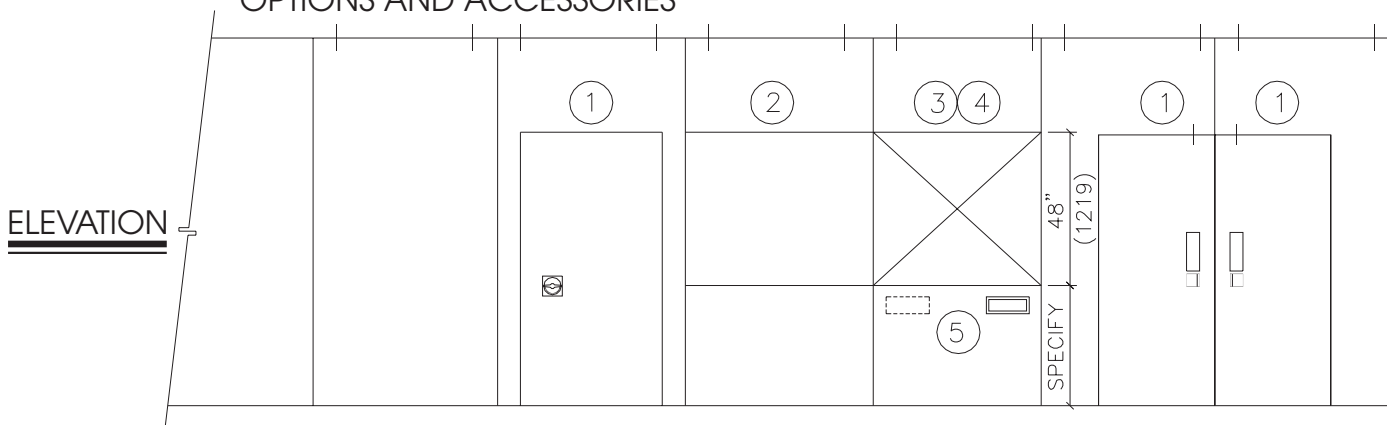

OPTIONS SPECIFICATIONS
 See page 8 for Product Specifications

- ① SINGLE PASS DOORS where indicated shall be nominally (specify: 3'0" (914); or 2'8" (813)) wide by (specify: 6'8" (2032); or 7'0" (2134)) high. Doors shall be manufactured of the same materials and thickness as the panels and be equipped with butt-type hinges and positive latches with drop cup and ring pulls. Double doors have roller latches. Options: deadbolt locks; self illuminated exit signs; hydraulic door closers; A.D.A. compliant friction roller latch with flush pulls.
- ② TACKBOARDS where indicated shall be nominally (specify: 48" (1219)) high; or full panel height). Tackboards shall consist of 1/4" (6) cork surfaced with minimum 30oz per lineal yard Type II Fabrictex vinyl fabric (color to be selected from manufacturer's standards) and bronze trimmed.
- ③ CHALKBOARDS where indicated shall be nominally (specify: 48" (1219) high; or full panel height). Chalkboards shall be chalkable porcelain enameled steel (color to be selected from manufacturer's standards) and bronze trimmed.
- ④ MARKERBOARDS where indicated shall be nominally (specify: 48" (1219) high; or full panel height) and be of suitable non-porous surfaced porcelain enameled steel for application of write-on, wipe-off marker pens. Color of markerboards to be selected from manufacturer's standards and bronze trimmed.
- ⑤ RECESSED TRAY for storing chalk or marking pens and erasers shall be installed where indicated and shall be bronze color.

FURTHER INFORMATION. All dimensions shown in parentheses are millimeters. **Moduflex Series 800** operable walls have four inch thick welded steel panels for high performance demanding applications and are supplied with Autoseal™ clearance type bottom seal mechanisms that are actuated automatically by moving one panel against the other. Optional Manual™ available. Scale N.T.S.



Moduflex® SERIES 800

Individual Panels Model 810 PP

TYPES OF CLOSURES AND PANEL STACKING

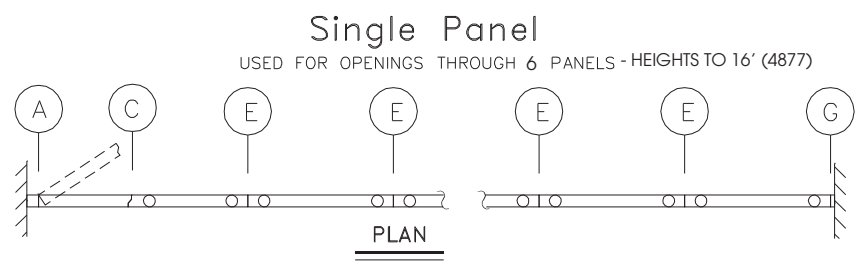
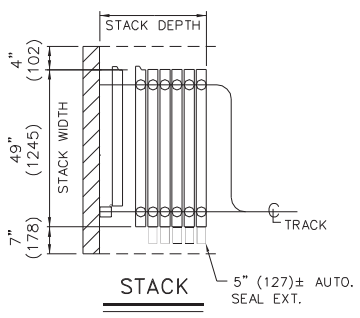

STACK DEPTH = NO. PANELS X 4.625" (117) PLUS 3 1/2" (89)

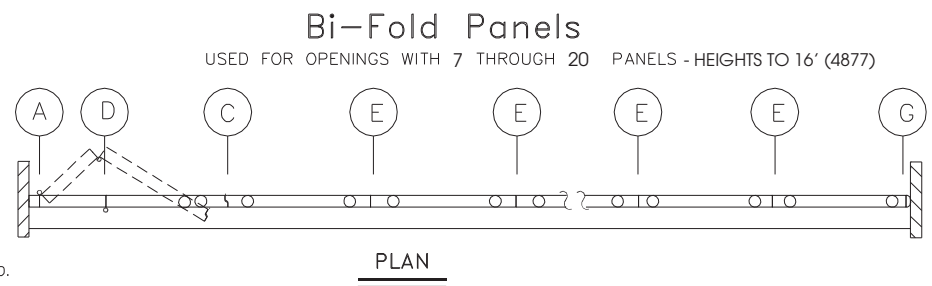
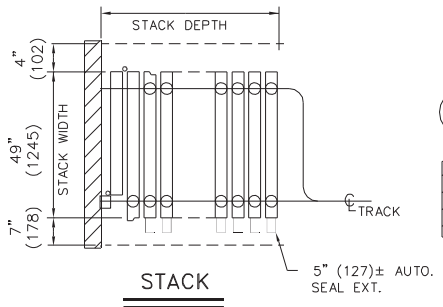

STACK DEPTH = NO. PANELS X 4.625" (117) PLUS 3 1/2" (89)

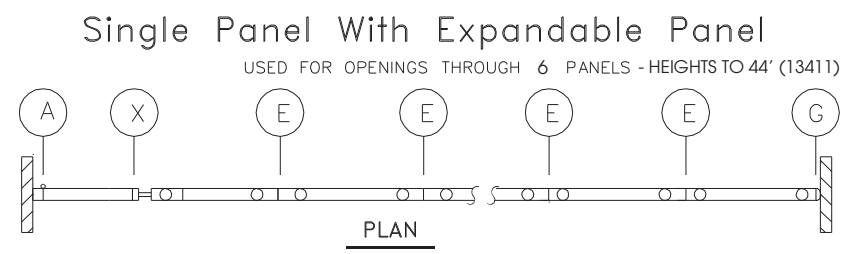
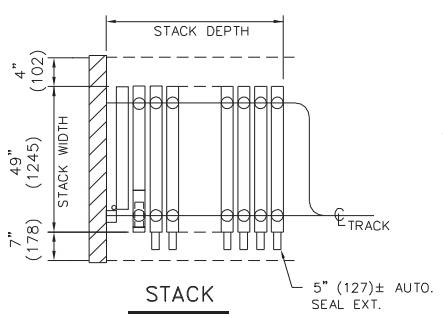

STACK DEPTH = NO. PANELS X 4.625" (117) PLUS 3 1/2" (89)
FOR HEIGHTS OVER 16' (4877), ADD 16" (808) FOR ANGLE STACK

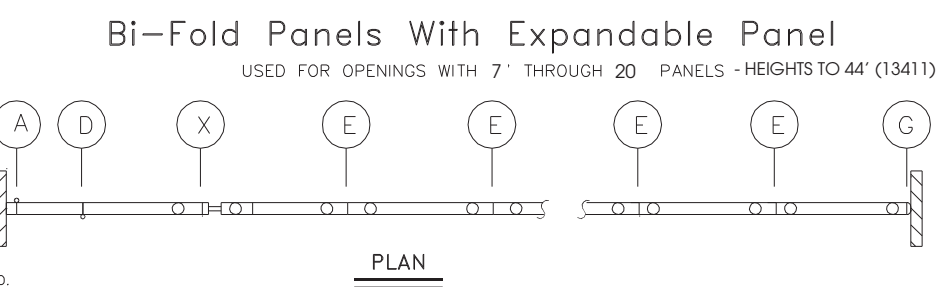
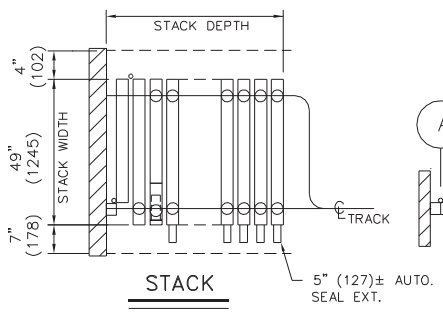

STACK DEPTH = NO. PANELS X 4.625" (117) PLUS 3 1/2" (89)
FOR HEIGHTS OVER 16' (4877), ADD 16" FOR ANGLE STACK

All dimensions shown in parentheses are millimeters. Scale: N.T.S.



Moduflex® SERIES 800

Individual Panels Model 810 PP

TYPES OF CLOSURES AND PANEL STACKING

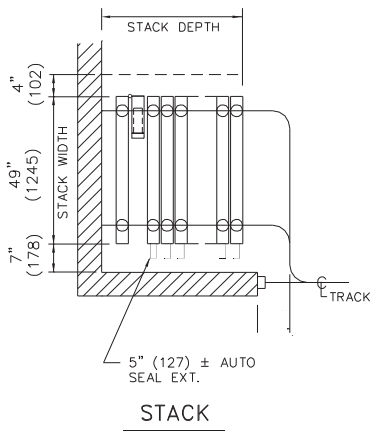

Expandable Fly Panel

USED FOR OFF-SET OPENINGS - HEIGHTS TO 44' (13411)

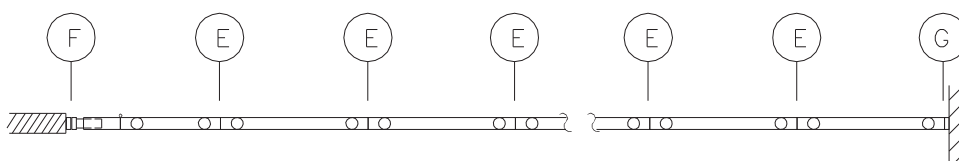

$$\text{STACK DEPTH} = \text{NO. PANELS} \times 4.625" (117)$$

FOR HEIGHTS OVER 16' (4877), ADD 16" (808) FOR ANGLE STACK

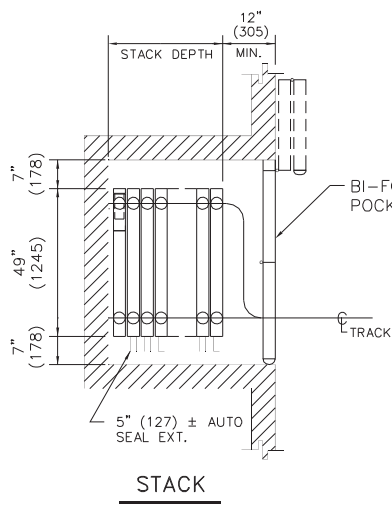

Expandable Panel

USED TO CLOSE TO POCKET DOOR - HEIGHTS TO 44' (13411)

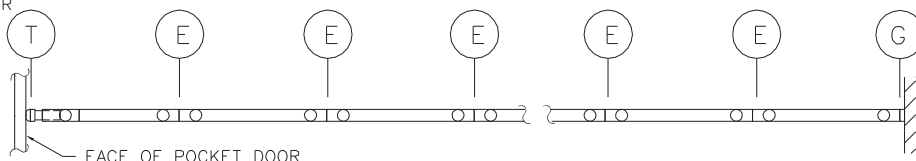

$$\text{STACK DEPTH} = \text{NO. PANELS} \times 4.625" (117)$$

FOR HEIGHTS OVER 16' (4877), ADD 16" (808) FOR ANGLE STACK

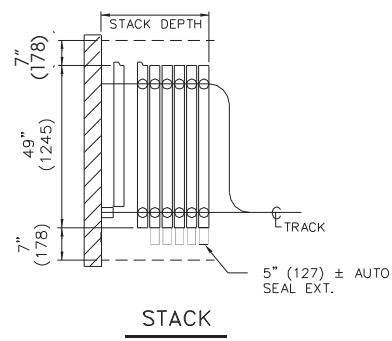

Communicating Panel

USED FOR OPENINGS THROUGH 13 PANELS - HEIGHTS TO 16' (4877)

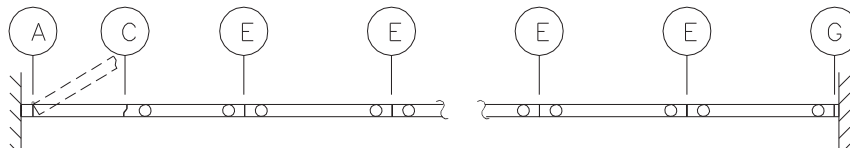

$$\text{STACK DEPTH} = \text{NO. PANELS} \times 4.625" (117) \text{ PLUS } 3 \frac{1}{2}" (89)$$



Moduflex® SERIES 800

Individual Panels Model 810 PP

JAMBS AND PANEL INTERLOCKING DETAILS

N.P.W. = NOMINAL PANEL WIDTH

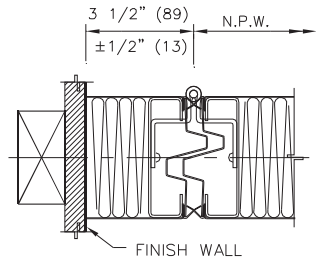

(A) ADJ. HINGED JAMB

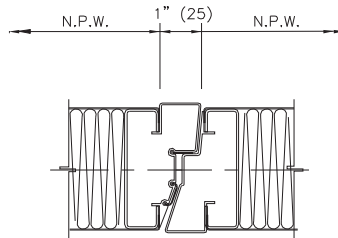

(C) CLOSURE DETAIL

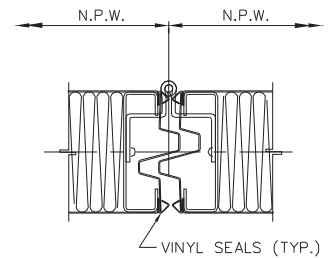

(D) HINGED INTERLOCK

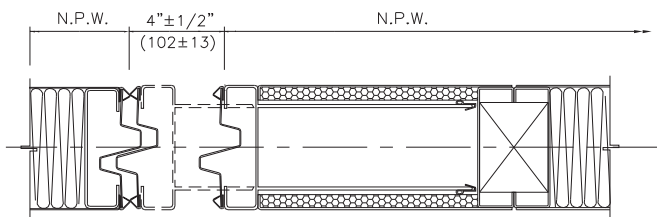

(X) EXPANDABLE PANEL WITH INTERLOCK

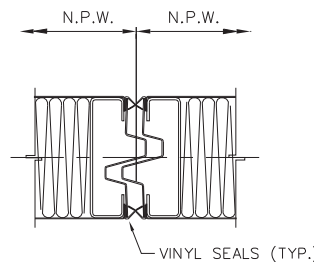

(E) INTERLOCK

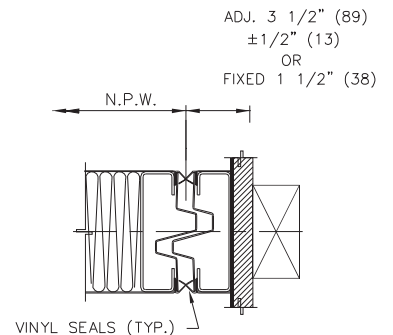

(G) LEAD JAMB

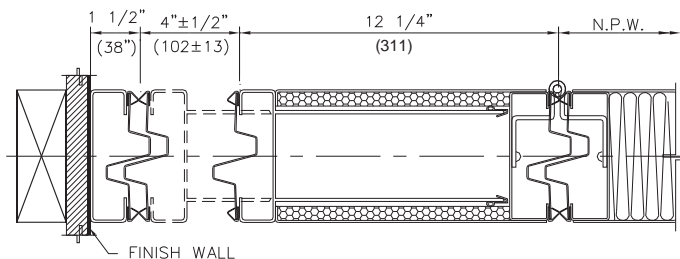

(F) EXPANDABLE FLY PANEL WITH INTERLOCK AT JAMB

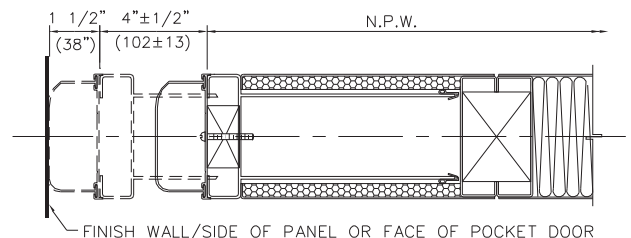

(T) EXPANDABLE PANEL WITH SOFT SEAL

All dimensions shown in parentheses are millimeters. Scale: N.T.S.



Moduflex® SERIES 800

Individual Panels Model 810 PP

VERTICAL SECTION - HEAD DETAILS - TYPE 7/8 ALUMINUM TRACK

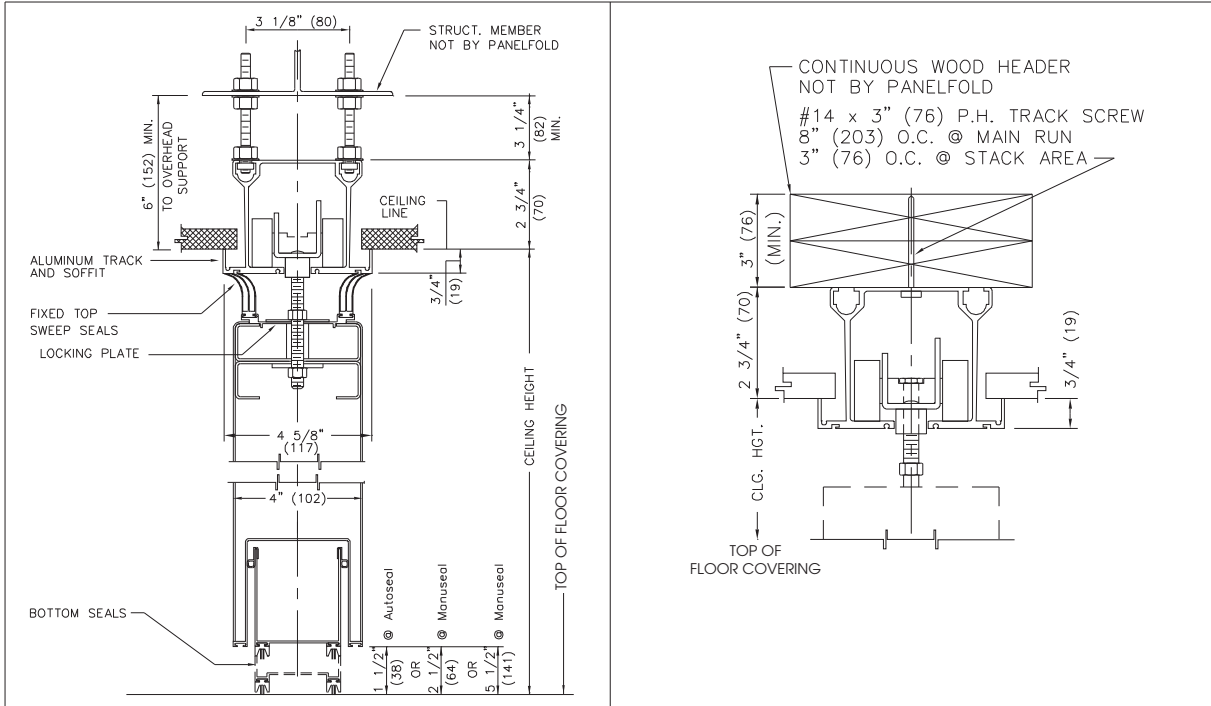

TYPE 7/8 TRACK HANGER ROD SUSPENSION

TYPE 7/8 TRACK DIRECT MOUNT

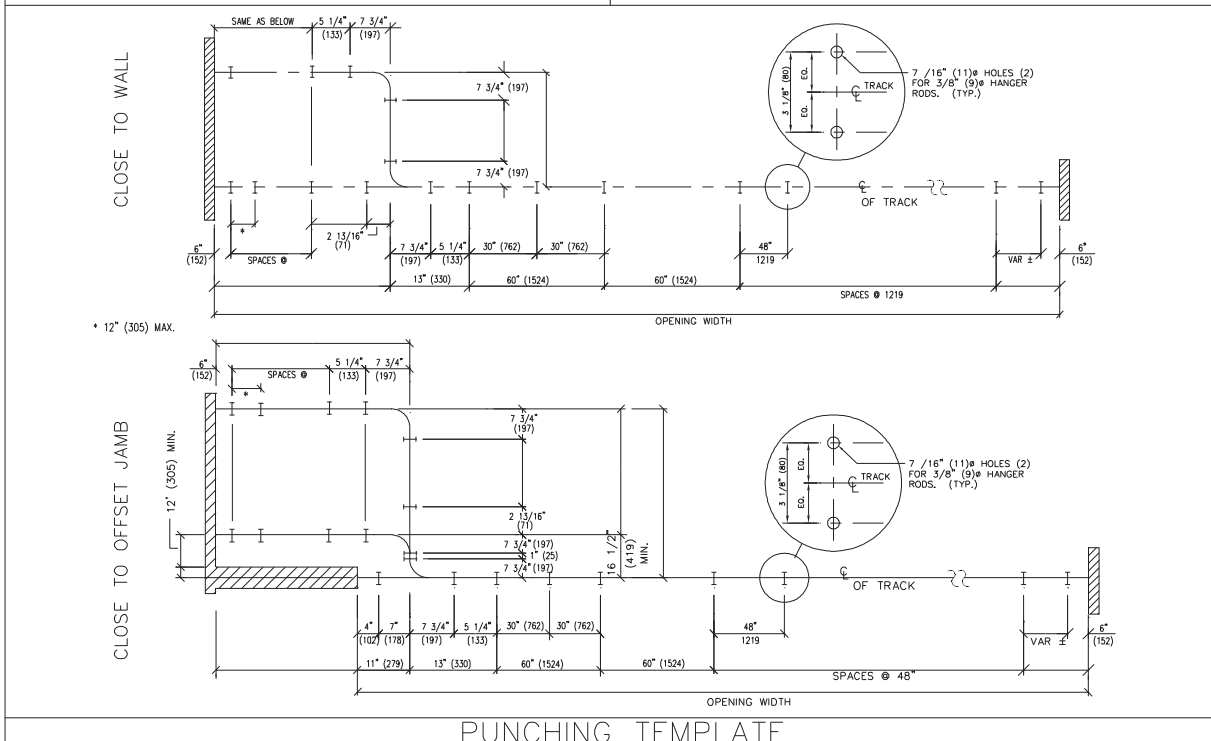

All dimensions shown in parentheses are millimeters. Scale: N.T.S.



Moduflex® SERIES 800
Individual Panels Model 810 PP

VERTICAL SECTION - HEAD DETAILS - TYPE 5 STEEL TRACK

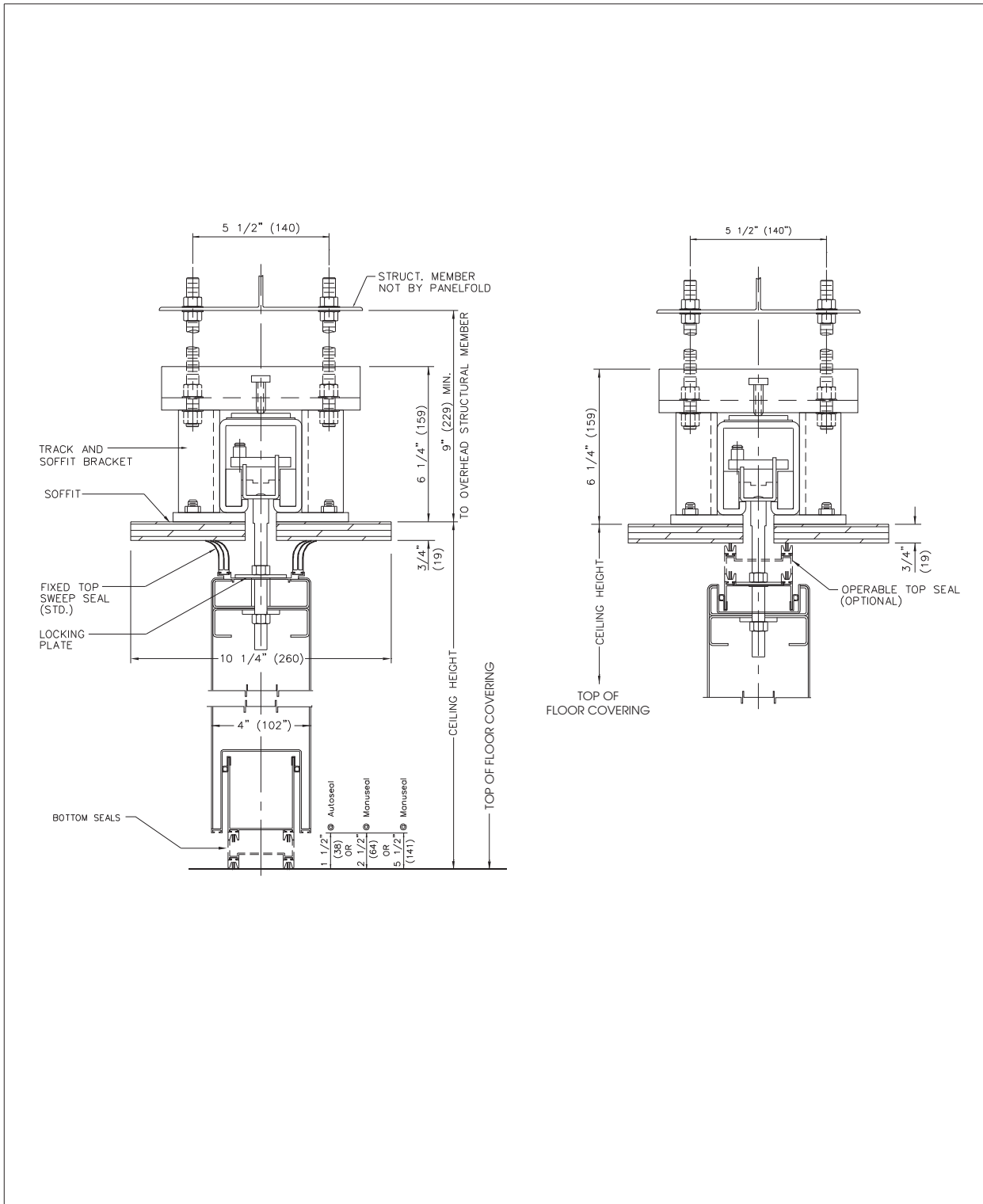

All dimensions shown in parentheses are millimeters. Scale: N.T.S.



Moduflex® SERIES 800

Individual Panels Model 810 PP

TYPE 5 STEEL TRACK PUNCHING TEMPLATE

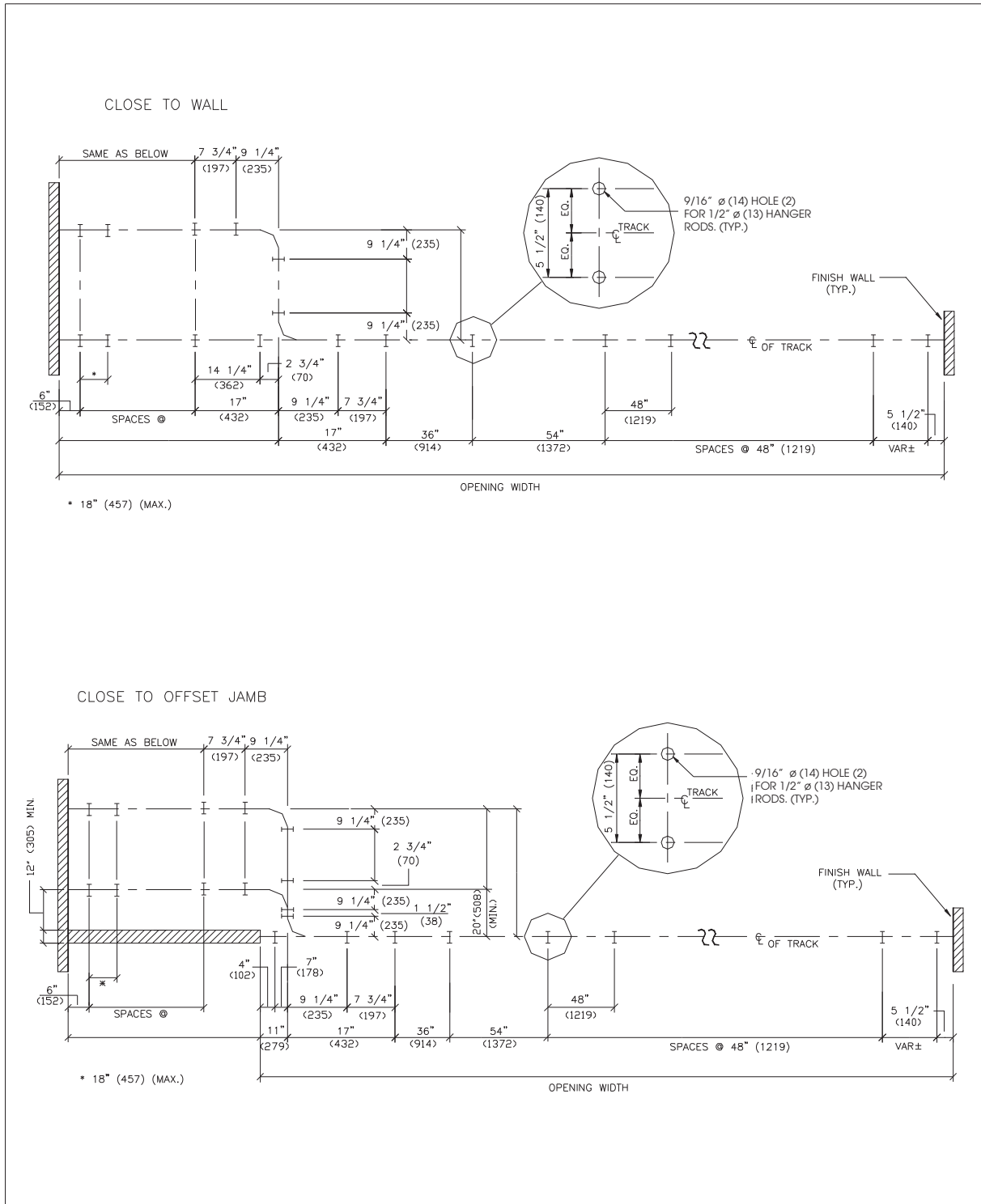

All dimensions shown in parentheses are millimeters. Scale: N.T.S.

Moduflex® SERIES 800

Individual Panels Model 810 PP (Pre-Programmed)

PRODUCT SPECIFICATIONS: SECTION 10650 - OPERABLE WALLS

PART 1 GENERAL

(See Project Guide Specifications for Scope, Related Work, References, Submittals, Product Delivery and Acceptable Manufacturers paragraphs.)

PART 2 PRODUCTS

2.1 OPERABLE WALLS shall be manufactured by Panelfold, Inc., Miami, Florida, U.S.A. and installed by an authorized representative of the manufacturer in openings prepared by others to Moduflex® Series 800 requirements.

2.2 OPERATION shall consist of a series of manually operated flat panels, top supported. Top and bottom seals shall be as specified in paragraph 2.9.

2.3 PANEL CONFIGURATION shall be as follows for areas indicated on the plans:

2.3.1 MODEL 810 shall be comprised of a series of pre-programmed, individual panels, side or remote stacking (located in room(s)).

2.3.2 Final closure shall be effected by (specify: Jamb-Hinged single or bi-fold Panels; Expandable Panels; or Jamb-Hinged Communicating Panels).

2.4 PANELS shall be one-piece 4" (102) thick, all-steel construction. Continuous steel panel faces shall be invisibly welded to minimum 14 gauge (1.90) one-piece steel frames. Horizontal or vertical spliced frames or faces shall not be permitted. Interlocking vertical panel edges shall be made of steel.

The vertical edges of the panels shall not require trim thus minimizing the appearance of the vertical joining of the Sheer-Look® panels.

2.5 PANELS shall be factory surfaced with one of the following (colors to be selected from manufacturer's standards):

2.5.1 Manufacturer's standard vinyl, Class A flame spread (specify Type I; or Type II).

2.5.2 Manufacturer's standard Ribtex® Basic, vertical-rib wall carpeting, Class A.

2.5.3 Manufacturer's Woventex® panel fabric, Class A, acrylic latex backed.

2.5.4 Maharam Tekwall panel fabric, Class A, acrylic backed.

2.5.5 Customer's Own Material to be factory applied (subject to approval by the manufacturer for suitability to standard manufacturing processes and equipment).

2.5.6 Coated steel panel faces for field surfacing by others.

2.6 HANGING WEIGHT of panels shall not exceed 12 lbs./ft² (58.6 Kg/m²).

2.7 ACOUSTICAL RATING as tested by an indepen-

2.8

dent acoustical laboratory in accordance with ASTM E90-81 test procedures in a full scale 14'0" (4267) by 9'3" (2819) opening shall be (specify: STC 54, STC 52 STC 49 or STC 47). Optional N.R.C. .90, STC 50.

ECHOSORB™ ACOUSTICAL WALL PANELS shall be provided where shown on the plans. Acoustical panels shall have obtained an NRC .75 rating per ASTM 423. Panels shall be provided with quick mounting and dis-mounting hardware requiring no tools. Acoustical transparent fabric to be selected from manufacturer's standards.

2.9

SOUND SEALS shall be as follows:

2.9.1 Vertical seals between panels shall consist of deep nesting, universal interlocking ESP bronze steel astragals incorporating continuous, vinyl acoustical seals. Vertical astragal vinyl seals shall be installed on the outboard edges of the panel skins in a double row with an acoustical labyrinth.

2.9.2 Horizontal TOP seals shall be (specify: continuous contact extruded vinyl shapes; or clearance type, automatically actuated; or clearance type, manually actuated).

2.9.3 Horizontal BOTTOM seals shall be (specify: 1 1/2" (38) clearance-type automatically actuated by the movement of one panel against the other; or 2 1/2" (64), or 5 1/2" (141) clearance-type manually actuated at waist height on panel edges). Downward pressure of all clearance-type seal mechanisms shall assure an acoustical seal and resist panel movement.

2.10 SUSPENSION SYSTEM shall be heavy duty aluminum Type 7/8 or steel type 5 track. Track shall be supported by adjustable steel hanger rods; or direct mount @ type 7/8 only. Panels shall be supported by trolley assemblies of radial type steel or nylon tired or carbon fiber fill tired, steel ball-bearing wheels. Trolleys shall be attached to the panels with adjustable steel pendant bolts with locks to prevent panel misalignment.

2.11 PANELS that are hinged together shall be hinged with manufacturer's standard butt-type hinges.

2.12 POCKET DOORS where indicated on the plans shall be manufactured of the same materials as the panels. Hinges shall be standard butt-type.

2.13 OPTIONAL U.L.® One Hour fire rated Firecoustic® models including full-thickness acoustical single and double pass doors, standard panel surfaces and intersecting walls shall be supplied where indicated on the plans.

PART 3 EXECUTION

(See Project Guide Specifications for Execution, Installation, Cleaning and Demonstration paragraphs).

NOTE: The ASTM - 84 procedure Class A flame spread and other test results referenced herein are for comparison purposes only and are not intended to reflect hazards presented by this or any other materials under actual fire conditions.

For further information, or additional technical information, contact your Panelfold distributor.

Panelfold®

FOLDING DOORS • ACOUSTICAL FOLDING PARTITIONS • ACOUSTICAL PANELS
OPERABLE WALLS • RELOCATABLE WALLS

Panelfold, Inc. P.O. Box 680130, Miami, Florida 33168
(305) 688-3501 • FAX: (305) 688-0185
Internet: www.panelfold.com • E-mail: sales@panelfold.com